

Solar Trough Organic Rankine Electricity System (STORES) Stage 1: Power Plant Optimization and Economics

November 2000 — May 2005

E. Prabhu
Reflective Energies
Mission Viejo, California

Subcontract Report
NREL/SR-550-39433
March 2006

NREL is operated by Midwest Research Institute • Battelle Contract No. DE-AC36-99-GO10337



Solar Trough Organic Rankine Electricity System (STORES) Stage 1: Power Plant Optimization and Economics

November 2000 — May 2005

E. Prabhu
Reflective Energies
Mission Viejo, California

NREL Technical Monitor: H. Price
Prepared under Subcontract No. NAA-1-30441-05

Subcontract Report
NREL/SR-550-39433
March 2006

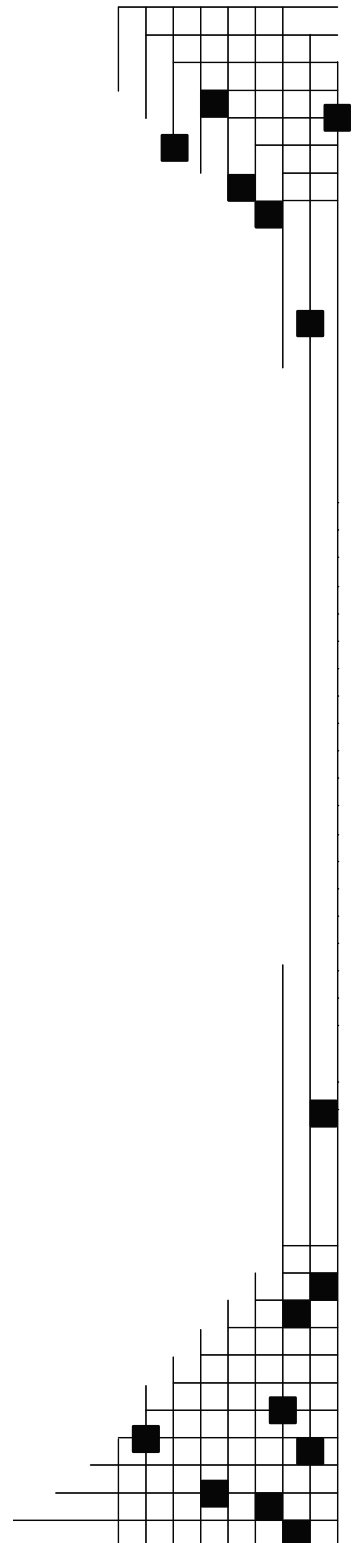

National Renewable Energy Laboratory
1617 Cole Boulevard, Golden, Colorado 80401-3393
303-275-3000 • www.nrel.gov

Operated for the U.S. Department of Energy
Office of Energy Efficiency and Renewable Energy
by Midwest Research Institute • Battelle

Contract No. DE-AC36-99-GO10337

**This publication was reproduced from the best available copy
Submitted by the subcontractor and received no editorial review at NREL**

NOTICE

This report was prepared as an account of work sponsored by an agency of the United States government. Neither the United States government nor any agency thereof, nor any of their employees, makes any warranty, express or implied, or assumes any legal liability or responsibility for the accuracy, completeness, or usefulness of any information, apparatus, product, or process disclosed, or represents that its use would not infringe privately owned rights. Reference herein to any specific commercial product, process, or service by trade name, trademark, manufacturer, or otherwise does not necessarily constitute or imply its endorsement, recommendation, or favoring by the United States government or any agency thereof. The views and opinions of authors expressed herein do not necessarily state or reflect those of the United States government or any agency thereof.

Available electronically at <http://www.osti.gov/bridge>

Available for a processing fee to U.S. Department of Energy
and its contractors, in paper, from:

U.S. Department of Energy
Office of Scientific and Technical Information
P.O. Box 62
Oak Ridge, TN 37831-0062
phone: 865.576.8401
fax: 865.576.5728
email: <mailto:reports@adonis.osti.gov>

Available for sale to the public, in paper, from:

U.S. Department of Commerce
National Technical Information Service
5285 Port Royal Road
Springfield, VA 22161
phone: 800.553.6847
fax: 703.605.6900
email: orders@ntis.fedworld.gov
online ordering: <http://www.ntis.gov/ordering.htm>



Printed on paper containing at least 50% wastepaper, including 20% postconsumer waste

Acknowledgements

We owe a deep debt of gratitude to Hank Price and Tom Williams of NREL, who were willing to bet on a concept that at the time was radical and contrary; Vahab Hassani of NREL, whose technical acumen kept me honest; Dave Menicucci and Craig Tyner at Sandia, who were willing to listen, and then to act; Tommy Rueckert, Jim Rannels and Gary Burch of the DOE, my mentors; John Brugman and Laurie Hardy of Bibb and Associates, for their process engineering genius; and Bob Martin of the DOE, who dared me to dare.

Table of Contents

1	Introduction.....	1
2	Scope of Work	1
3	Description of Strategy and Processes Used.....	2
4	Reporting Details	2
4.1	Steam-ORC Comparison	4
4.2	Heat Rejection Study	7
	Forced Draft Air-Cooled	9
	Natural Draft Air-cooled and Water-Cooled Systems	10
4.3	Working Fluid Evaluations.....	14
4.4	Power Plant Optimization.....	27
4.5	Power Plant Conceptual Design and Cost Estimate	29
4.6	Field and Storage Evaluation and Conceptual Design Report.....	43
4.7	Host Site Selection and Market Potential Report	46
	California Opportunities	46
	Arizona	48
	Other States	49
	Worldwide Opportunities	50
	Conclusion: Market Opportunities	50
4.8	Economic Evaluation.....	50
4.9	Planning for the First STORES Power Plant.....	53

Executive Summary

Preamble

The National Renewable Energy Lab awarded **SUBCONTRACT NO. NAA-1-30441-05** to Reflective Energies as a result of its competitive solicitation to find pathways to solar thermal power. The subcontract was to perform a study that would further develop the concept of the Solar Trough Organic Rankine Cycle Electricity System (STORES) through a Stage 1 Study. The objectives of the proposed work are as follows: 1) develop an optimized ORC power cycle for integration with a parabolic trough solar field, 2) develop a conceptual design and cost estimate for a 10 MWe STORES system, 3) conduct a performance and economic assessment of pilot and mature STORES plants, 4) conduct preliminary assessment of STORES market potential, and 5) identify next steps towards a demonstration or early commercial STORES project.

Background

Solar Trough Power Plants began very successfully, with nine plants and a total of 354 megawatts on line within a few years in the late 1980s. These plants (known as SEGS¹ Plants I through IX) have performed very well over the last twenty years, generating power all year, but especially during the peak summer months. Their expected life is at least thirty to forty years. They have generated far more power than all other solar technologies combined. Their longevity has also exceeded most other solar. Sadly, despite this success, no more plants have been built since then.

A New Proposition for Solar Trough Power Plants: Smaller is Better

This study investigated a new pathway towards commercialization of solar trough power plants, a system dubbed STORES (Solar Thermal Organic Rankine Electricity System). The prevailing wisdom was that in order to be economic and successful, solar trough projects had to be larger, or integrated with natural gas plants, creating economies of scale. This study examined the opposite proposition. It postulated that a large solar

¹ Solar Electric Generator

plant would take large capital expenditure and suffer long delays, as witnessed by several such projects proposed in many countries, none of which has been built. However, a small solar trough power plant could be built quickly, provide local value, meeting a local customer's needs. Rather than generate power for the wholesale market, STORES would focus on the retail market, because local value and prices may be higher. With proper optimization, such plants could be modularized, thereby achieving economies of production. They could be automated, and if the market existed, scaled up to larger sizes or scaled down to even smaller sizes, depending on the customer's needs.

Technological Barriers

There were many technical barriers to overcome. The original nine plants were built with no precedent to guide them, learning as they went along. Given the circumstances, the achievement was all the more creditable. They used conventional steam turbine power plants for converting heat to electricity, and addressed the challenges of steam generation by going to bigger sizes, finding larger turbines, and fewer employees per megawatt. Furthermore, they were allowed to use up to 25% natural gas. Storage was not rewarded by higher pricing, and except for SEGS I, storage was not built into these plants. The plants were well designed, but power was expensive to produce, and when the strong price supports of the 1980 PURPA regulations collapsed, no more power plants were constructed. The support industry withered, and only small producers survived, helping to replace broken parts for maintenance.

STORES needed to develop a power plant that could be used for small solar power plants. Steam technology was no longer available in small sizes. An alternative approach was to consider Organic Rankine Cycle (ORC) power systems that have been used very successfully for geothermal power plants for decades. There was also reason to examine whether the relatively low temperature of the resource could be better harnessed. Several process designs were considered to maximize efficiency, and several potential ORC suppliers were considered, particularly those who have previously supplied components or systems to the geothermal industry. Geothermal fluid, like the solar trough plants, is also relatively low temperature (300 F to 500 F), but there are

important differences; geothermal fluid should be drained of all its energy before returning it to the earth, whereas solar heating fluids are recirculated through the troughs; high residual heat means lower new solar heat required. This study performed an optimization between ORC systems and solar troughs. Several important thermodynamic variations were identified, with efficiency and operating considerations. In the same vein, several solar thermal fluids and several ORC fluids were considered, with several, cascade and multiple cascade cycles. Another variable considered was the series-parallel arrangement of trough assemblies and the impact they have on the cycles being evaluated.

A STORES plant that is technically optimized is a two tier cascade system, with toluene as the upper working fluid and butane as the lower working fluid. The solar heat fluid (HTF) with this system is Therminol VP-1, similar to most of the SEGS plants. These plants would be capable of automatic startup, safe shutdown, and regulation with varying solar conditions. They may not produce as much as manned power plants, but the savings in labor would more than compensate for the loss of a few kilowatt hours each day. The plants would not require any other fuel, and use only small amounts of electricity when they are not in operation.

The Market for STORES Plants

An important part of the study was to determine whether there is a market for STORES power plants. Without a market, the best technologies will fail. The first attempt was to find off-grid communities in the Southwestern US that could benefit from 1 to 10 MW of electricity. The plant would include storage, allowing delivery of power around the clock. The notion was that off-grid consumers are often willing to pay much higher prices for electricity. This effort was not successful. The investigation found that all communities that could use a megawatt or more were already hooked up to the grid. While there is no market for STORES power plants off-grid in the U.S., it is quite likely that in the Saharan region of Africa and in the middle-east, there are several remote communities that do not have electricity at all, and would benefit from STORES power plants that have built-in storage.

The next effort was to find grid-connected customers with large loads who were concerned about electric reliability and who were paying high prices for electricity. These customers also required large, flat land areas and high quality direct normal solar radiation.

Several potential customers were found. Among them are US military bases, National Forests and Parks, and Native American lands. Many of these entities expressed a strong interest in STORES power plants of the size proposed, where the power would offset their grid usage, saving the most power at peak summer prices. The key considerations were dependable power, long term price stability and reasonable costs. With the stellar track record of the SEGS power plants, these considerations could be satisfied.

An alternative approach was to look for customers who were required to meet renewable energy portfolio thresholds. One electric utility (APS) interested in meeting its portfolio standards through solar was very interested in the STORES technology. APS met several times with Reflective Energies, and even visited a geothermal power plant at Reflective Energies' request. Subsequently, APS issued an RFP for a one-megawatt STORES power plant. Three bidders were selected, three bids received, from which one was chosen. That power plant, known as the Saguaro Power Plant in Arizona, is now under construction. APS will consider several more such plants as it ramps up to meet its renewable portfolio requirements. Other customers are expected to follow.

STORES has indeed gone from concept to reality, as envisioned in the proposal.

Cost Considerations

The capital and O&M costs for STORES power plants were examined. It was estimated that the first plant would cost an estimated \$5,000 a kW, or about \$27,500,000 for a five megawatt plant with an additional \$2,500,000 for first-of-a-kind engineering and startup of the first plant. Each subsequent plant would drop in cost by an estimated 3 to 5 percent, as experience and increased production favorably impact costs.

Smaller power plants, such as a one-megawatt plant, were estimated to have a higher first cost, about \$9 to 10 million, with the same first-of-a-kind engineering and startup costs. Even at the comparatively high first cost, with low interest, long term loans the annual component of these costs is acceptable for power displacing retail pricing.

There were several challenges related to O&M costs. The current SEGS plants have an O&M composite cost range of about \$0.05 to 0.07 a kWh. Being much smaller, a STORES power plant would have a much higher O&M cost if it used the same staffing. If the plant fully was automated, it would have no regular staffing at all. A special effort was dedicated to examining this notion. The effort included operators, engineers and managers from a SEGS facility. After much debate, each of the skeptics was convinced that automated STORES plants were feasible, even desirable. A remote display and control station would be available offsite, at a manned local substation or other control room. This remote control could be transferred to any computer set up to manage the power plant. This automation would probably result in operation slightly less optimal than manned operation, and therefore cost a few kilowatt-hours in output each day. However, the automation would save a lot of money in reduced labor costs, particularly for the smaller STORES power plants, more than offsetting the lost production and related revenue. The estimated O&M costs are about \$0.05 a kWh.

Conclusion and Recommendations

STORES power plants offer a new pathway towards commercialization of solar trough power plants. Instead of moving to larger power plants or plants that are integrated with natural gas, STORES plants would stand alone, providing electricity for customers who need it most. Rather than benefit from economies of scale, STORES plants would benefit from economies of production and modularity. STORES plants would provide power where possible at retail rates that are two to three times wholesale rates. Where feasible, STORES plants could use storage, although in the Southwestern U.S. this was not found to be of value. It may be vital, however, in developing countries, such as in the Sahara or Middle East.

As a direct result of this study, the first STORES plant is already in construction. It is the first solar trough power plant in the US in twenty years. The customer is interested in more such plants, and there are many other potential customers. It is hoped that several STORES plants will follow. By providing the building blocks for the revival of solar troughs, STORES power plants also offer the potential for larger solar power plants to be constructed.

Solar troughs already provide more solar-derived electricity than any other type of solar energy. STORES will help it to grow. Solar power will be able to provide a large portion of the energy needs of the southwestern US, and in many other countries, helping towards energy independence, reducing emissions and greenhouse gases.

1 Introduction

The goal of this study is to develop a new pathway towards resurrecting and commercializing Solar Trough power plants. There are several organizations that are pursuing the development of large Solar Trough based steam plants (100 megawatts or larger). This study examined whether there is a pathway to success that uses smaller, modular, solar trough based power plants as an alternate approach to large central plants. This report fulfills the requirements of Subcontract No. NAA-1-30441-05 between the National Renewable Energy Lab (NREL) and Reflective Energies. Previously, Reflective Energies had developed a concept known as STORES (Solar Thermal Organic Rankine Electricity System), as part of an earlier subcontract with NREL. Under that earlier effort, it was found that the STORES concept had much potential but that several issues were still to be resolved. The current work is known as the STORES Stage I study, with the goal of developing an optimized ORC Power cycle, a conceptual design and cost estimate for a STORES system, and a preliminary assessment of the market potential, and setting the stage for the first STORES demonstration plant.

The objectives of the work are as follows: 1) develop an optimized ORC power cycle for integration with a parabolic trough solar field, 2) develop a conceptual design and cost estimate for a 10 MWe STORES system, 3) conduct a performance and economic assessment of initial and mature STORES plants, 4) conduct preliminary assessment of STORES market potential, and 5) identify next steps towards a demonstration or early commercial STORES project.

2 Scope of Work

The Scope of Work for this subcontract is shown below:

- A comparison of steam Rankine and organic Rankine power cycles
- An evaluation of heat rejection options for ORC systems
- An assessment of working fluids for the solar field and ORC systems
- The optimization of organic Rankine power cycles for solar resource temperatures
- Detailed conceptual ORC power plant design
- Development of an optimized solar field and power plant

- Identification of a potential demonstration plant and preliminary market assessment
- Economic and financial assessment of demonstration plant
- Development of SOW for next steps towards commercialization of STORES power plants.
- Generation of a final report.

3 Description of Strategy and Processes Used

There were two basic strategies used in this study, and they were pursued in parallel.

- The first was to find the most suitable power plant in the range of one to ten megawatts, from a technical perspective. This was achieved by combining the skills of solar experts and geothermal power plant experts. Geothermal power plant experts have long been able to design power plants that take advantage of low temperature resources. They began to use the Organic Rankine Cycle (ORC) for several geothermal plants a few decades ago. Their expertise was crucial in coming up with optimum solar cycles
- The second strategy was to find potential clients in the sun-belt that would be able to use solar energy from Trough type power plants and to determine their needs. Rather than build large solar plants for supplying power to the grid at wholesale energy prices, this strategy considered smaller power plants that would sell electricity to a customer currently paying retail prices, which are much higher than wholesale power prices.

Whereas initially it was anticipated that likely customers would be off-grid, where storage would be of value, it was found that most potential customers already received grid power, but for several reasons would benefit from solar power as well. This finding changed the course of the study significantly, resulting in a new design

4 Reporting Details

This study was performed in nine stages, with the tenth stage being the integration of the previous nine to reach conclusions and provide a course of action.

The nine tasks that were to be performed and reported on were drawn from the Contract Statement of Work and are as follows:

Task 4.1: Steam-ORC Comparison Interim Report: The report will summarize the results of a comparison between the reference cascade ORC cycle and a steam cycle using similar solar resource conditions. The report will include heat balances, details of process flow, a list of equipment, and a summary of the assumptions for key components.

Task 4.2: Heat Rejection Study Interim Report. – This report will evaluate the feasibility of the cooling systems identified in task 4.2. The report will consider first order costs, the practicality for the intended application, and compare the impact on reference system parasitics, cycle efficiency, and cost.

Task 4.3: Working Fluid Study Interim Report. – This report will identify the ORC working fluids that are stable, optimized for the cascade cycle. The primary focus will be on the higher temperature ORC loop. The report will also evaluate various heat transfer fluids that could be used in the solar field.

Task 4.4: Power Plant Optimization Report – This report will summarize the optimization of the cascade ORC cycle for a solar application. It will show a comparison of various design options and evaluation based on rough first costs verses performance trade-offs.

Task 4.5: Power Plant Conceptual Design and Cost Estimate – This package will include drawing, plant descriptions, renderings, performance curves, and cost estimates.

Task 4.6: Field and Storage Optimization and Conceptual Design Interim Report. This report will summarize the design optimization of the solar field and thermal storage system. The report will summarize the evaluation of 2-tank vs. thermocline storage, optimization of solar field and thermal storage system sizes, discuss safety issues, and include detailed solar plant cost and design.

Task 4.7: Host, Site Selection and Market Potential Interim Report. – This report summarizes the selected host application systems requirements, review key features of the selected project site and summarizes results of market assessment.

Task 4.8: Economic Evaluation Interim Report – This report defines the methodologies used to evaluate project economics. Includes assessment of economics for the selected project.

Task 4.9: Stage 2 Project Planning Interim Report – The report defines the actions to be completed in the next phases of this effort to develop and test a demonstration plant.

As the study progressed, some of the tasks above had to be tailored to match the findings of the study. For example, when it was found that storage did not add high value for the additional cost, but plant sizing flexibility was important, the study was modified to include greater plant flexibility, and to maximize output without storage.

4.1 Steam-ORC Comparison

In order to establish a baseline for comparison between steam and organic cycles, the meteorology of several potential locations was considered, and the site of the Kramer Junction Power Plant was chosen for comparison purposes.

Figure 4.1.1 shows the annual Insolation Mantle for the Kramer Junction area.

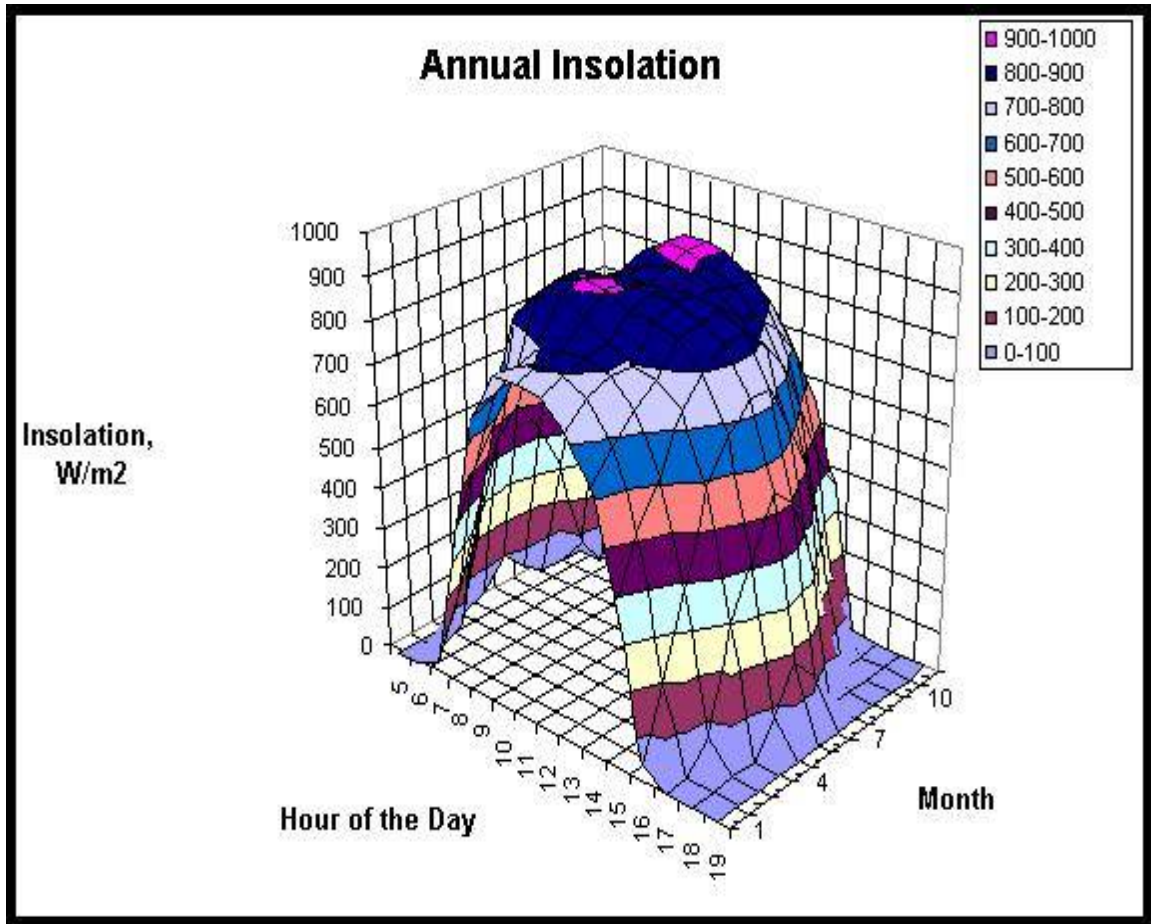

Figure 4.1.1 Annual insolation mantle for Kramer Junction area

Temp.	Cycle and Fluids	Thermal Efficiency, %			
		Steam		ORC	
		gross	net	gross	net
560 °F HTF					
	Steam Simple Cycle vs. ORC Simple Cycle Butane	26.6	24.3	15.6	14.5
	Steam Reheat vs. ORC Cascade Cycle Cyclohexane/Butane	27.8	25.6	27	19.3
	Steam Reheat vs. ORC Cascade Cycle Toluene/butane	27.8	25.6	27.6	21
	Steam Reheat+ Extraction vs. ORC Recuperative+ Cascade Cycle Cyclohexane/Butane	30.3	28.2	30.9	21.1
	Steam Reheat+ Extraction vs. ORC Recuperative+ Cascade Cycle Toluene/Butane	30.3	28.2	31.3	23.9
735 °F HTF					
	Steam Simple Cycle vs. ORC Simple Cycle Butane	30.3	27.9	15.6	14.5
	Steam Reheat vs. ORC Cascade Cycle Steam/Butane	32.2	29.9	32	26.9
	Steam Reheat vs. ORC Cascade Cycle Toluene/butane	32.2	29.9	29.2	22.5
	Steam Reheat+ Extraction vs. ORC Recuperative+ Cascade Cycle Steam/Butane	37.3	34.5	33.7	27.6
	Steam Reheat+ Extraction vs. ORC Recuperative+ Cascade Cycle Toluene/Butane	37.3	34.5	35.4	28

Fig. 4.1.2: Comparison of Steam and Organic Cycles

A comparison of steam and organic cycles for baseline conditions is shown in Figure 4.1.2 for two temperature thresholds, a peak of 560 F (the current practical maximum for storage) and a peak of 735 F (the practical maximum when storage is not required). For this study, it was assumed that the temperature difference between the hot HTF fluid and the cold HTF fluid is 85 F, representing a compromise between the conflicting goal of maximizing average HTF temperature and minimizing HTF volume. It is seen that even though careful design and fluid choice increase the performance of the ORC systems, at the average summer high temperature conditions, the steam cycle outperforms the ORC by 15% to 25%. However, there are other benefits of the ORC which make it a viable alternative to the steam cycle in specific applications. These benefits include: the ability to scale to smaller unit sizes, higher efficiencies during cooler ambient temperatures,

immunity from freezing at cold winter nighttime temperatures, the ability to remain above atmospheric pressures, particularly at lower temperatures, and the adaptability to semi-attended or unattended operations.

The potential for using steam as the working fluid for the upper stage of the cascade cycle was also considered. Toluene may be able to compete with steam as the upper stage working fluid. Although the extraction/reheat steam cycle remains the standard of comparison for larger trough solar facilities, innovative ORCs present a viable alternative for site-specific cases and approach the steam cycles in performance. Task 4.3, which look at working fluids, evaluates a larger variety of ORC options.

Figure 4.1.3 shows a simple organic cycle, and Figure 4.1.4 shows a cascade organic cycle.

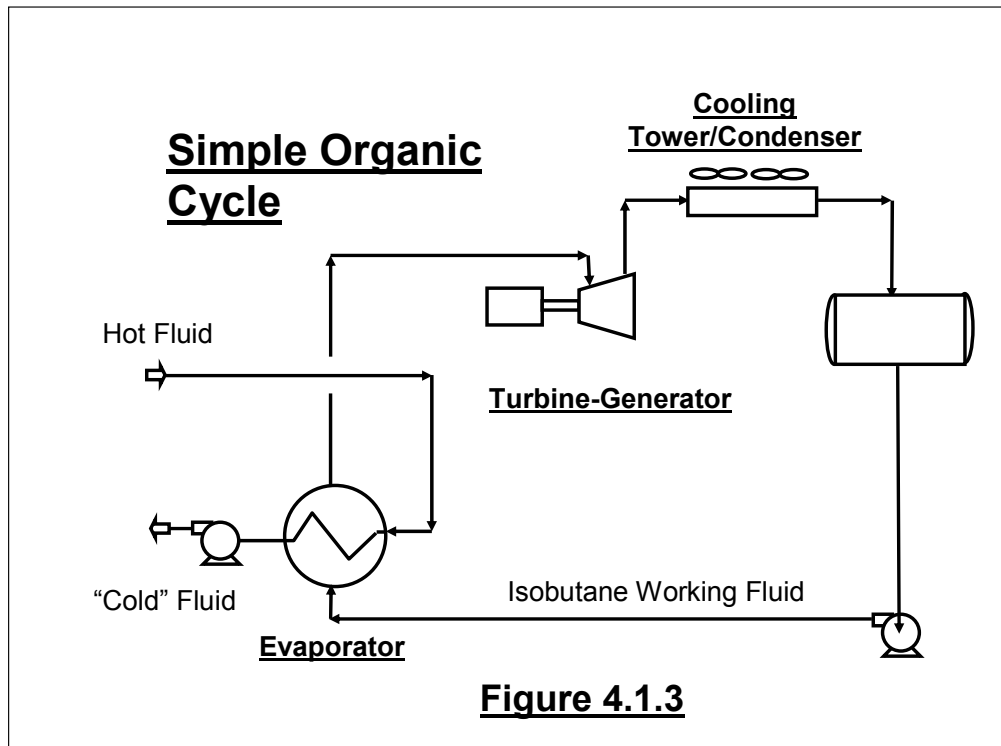

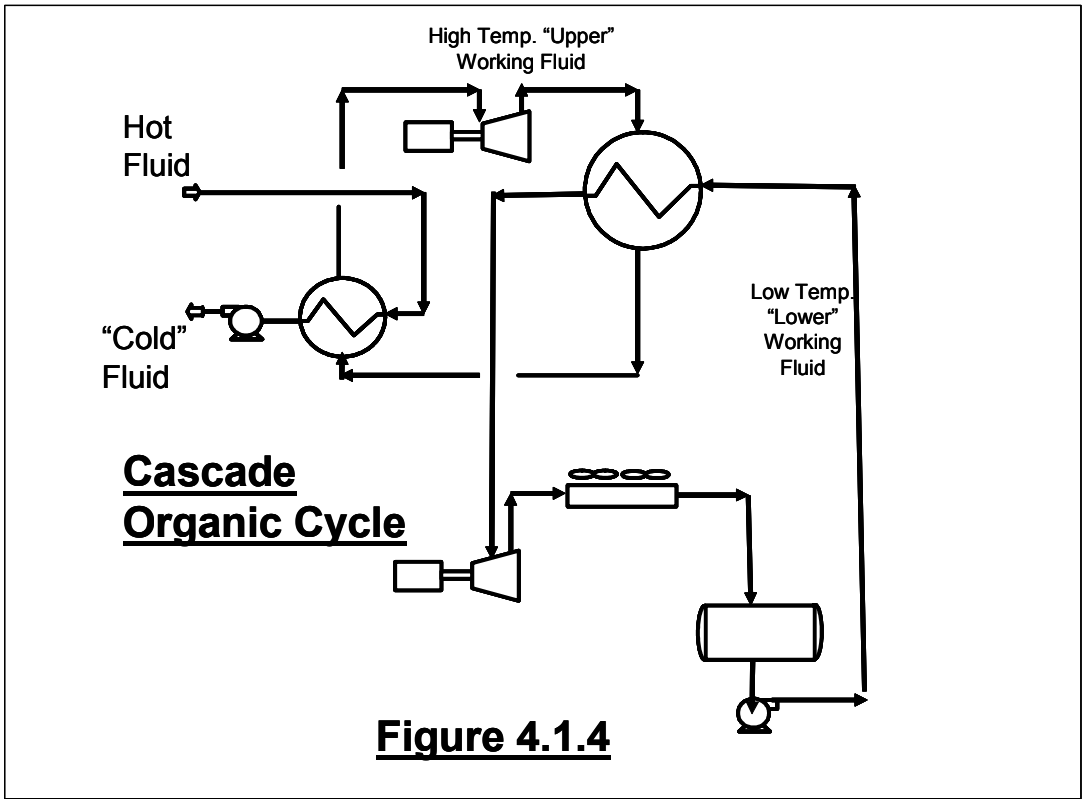

4.2 Heat Rejection Study

An essential part of the Rankine Cycle for power generation is that waste heat must be disposed of, known as heat rejection. Heat is rejected into heat sinks. The colder the temperature of the heat sink, the more power that can be extracted from the energy source. Heat sinks allow power plants to generate more power for the same energy input, and thus operate more efficiently. The following is a general description of each of the heat sink technologies that will be evaluated.

Water-cooled (with mechanical draft cooling tower)

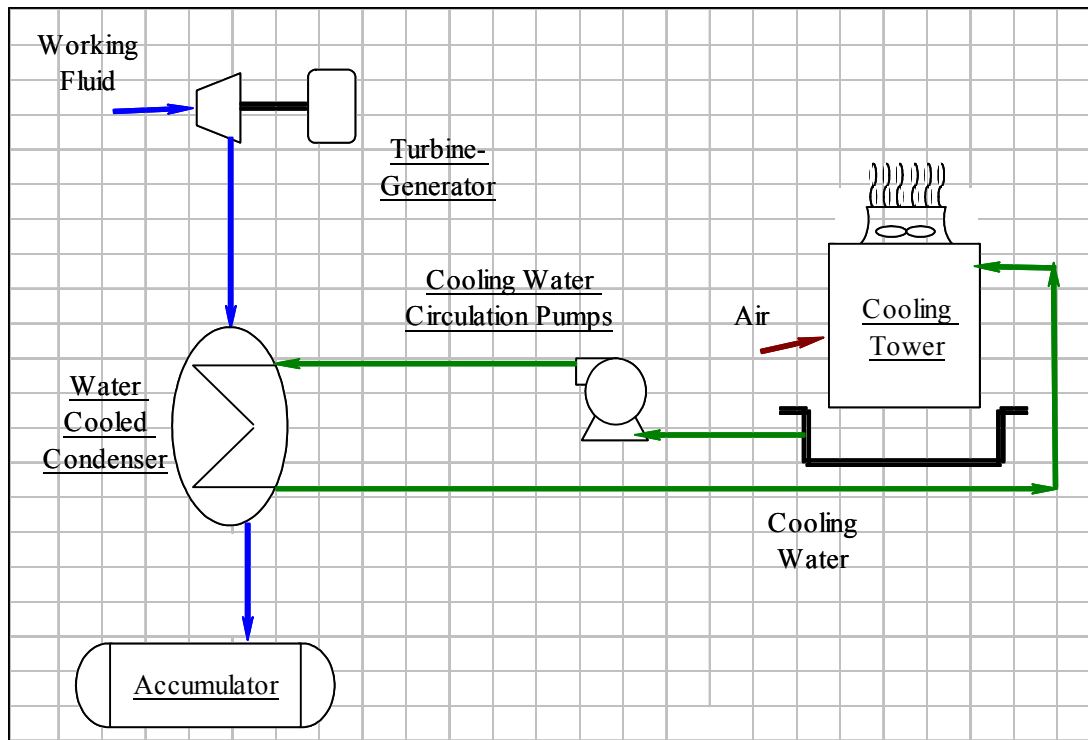

Figure 4.2.1: Water Cooled Heat Sink

Figure 4.2.1 shows a process flow diagram for a water-cooled heat sink. In this type of heat sink, the working fluid from the turbine discharge flows to a water-cooled condenser after being discharged from the turbine. As the working fluid condenses, its heat energy is transferred to the cooling water. The condensed working fluid drains to the working fluid accumulator, whence it is pressurized with “condensate pumps” and “feed pumps”, heated and evaporated prior to re-entering the turbine.

“Circulating” water pumps force cooling water through the condenser and up to the top of a mechanical draft cooling tower. The mechanical draft cooling tower has fans that draw ambient air past the falling water, cooling it by evaporation similar to a swamp cooler.

Forced Draft Air-Cooled

Figure 4.2.2 shows a process flow diagram for a forced draft air-cooled heat sink.

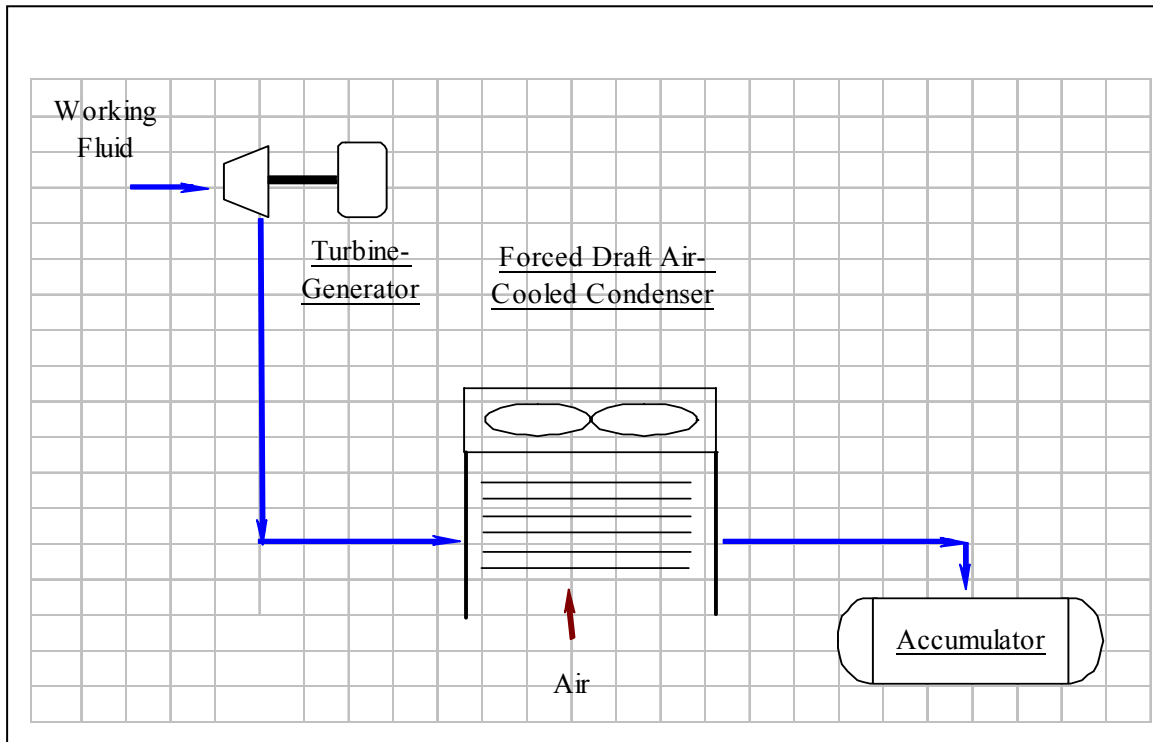

Figure 4.2.2: Forced Draft Air Cooled Heat Sink

Air Cooled Sinks do not utilize water as a cooling medium. Instead, the working fluid is cooled directly by air. Fans draw ambient air past tube bundles which contain the condensing working fluid. This technology requires no water and is simpler to operate than a water-cooled heat sink. Like water-cooled systems, forced draft air-cooled systems are used in many geothermal ORC power plants.

Natural Draft Air-cooled and Water-Cooled Systems

Figure 4.2.3 shows a process flow diagram for a natural draft air-cooled heat sink.

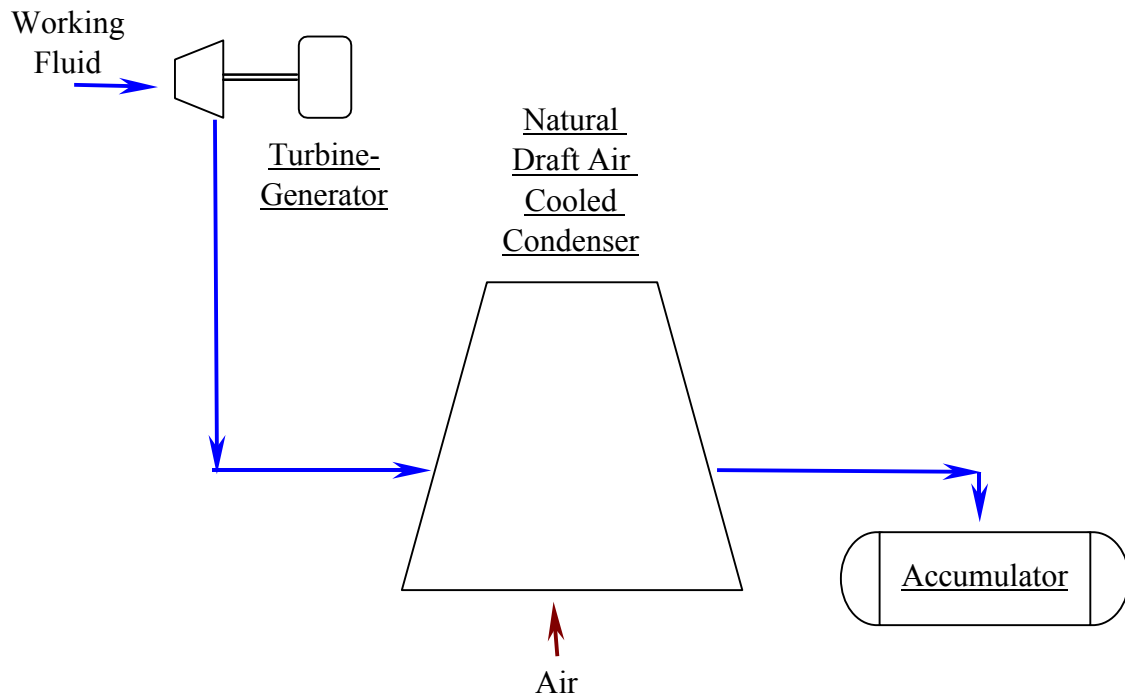

Figure 4.2.3 Natural Draft Air-Cooled Heat Sink

Natural draft air-cooled and water cooled systems require no cooling fans, relying on natural air flow through long cooling towers that are symbolic of nuclear power plants. They are often used when the use of cooling water and power is expensive. The cooling tower must be several hundred feet tall in order to generate the needed draft, making these systems particularly expensive for small plants. Induced draft cooling towers together with water cooling are common in large nuclear power plants in the Eastern and Midwestern U.S.

METHDOLOGY

In order to make a valid comparison between the various heat rejection technologies, each cycle must be compared at equivalent ambient conditions. The average, summer, daytime (i.e., daylight hours only), dry-bulb temperature at nearby Edwards Air Force Base was found to be 89 °F. The coincident wet bulb temperature was 62 °F. Each heat sink technology was compared at these conditions.

The power output of an ORC power plant increases as working fluid condensing temperature decreases. Organic rankine cycles were modeled using a commercial process simulator program, HYSIM. Using HYSIM, a relationship between the condensing temperature of the working fluid and the gross cycle power was established. This relationship is shown in Figure 4.2.4 for a ten megawatt plant, but would be roughly the same for any other Rankine Cycle power plant.

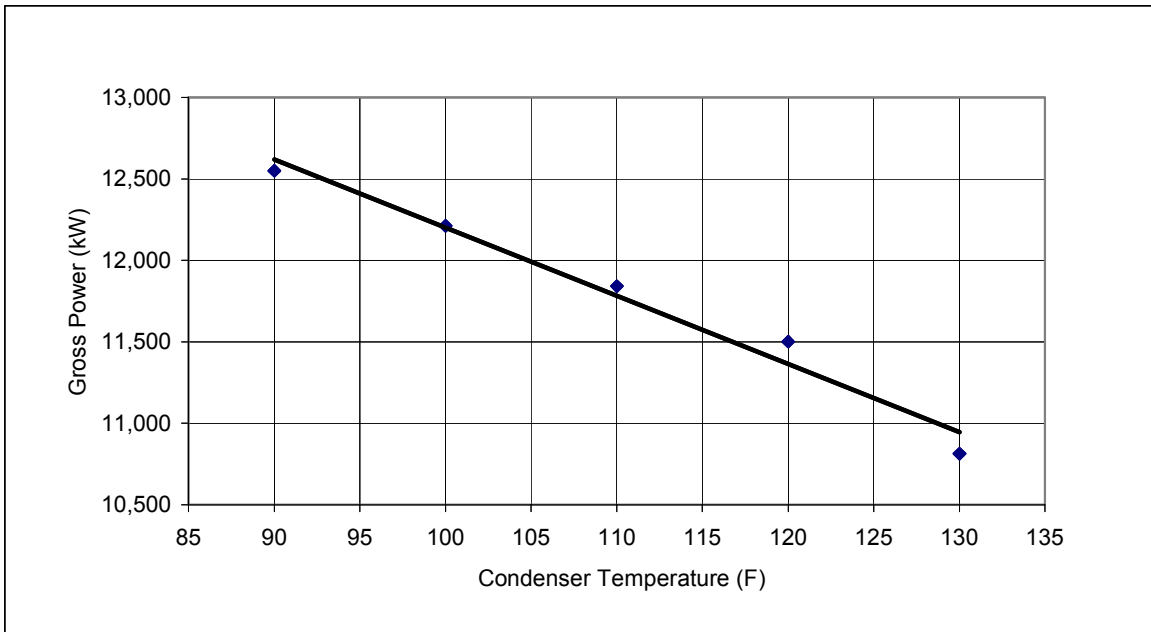

Figure 4.2.4. Cycle Gross Power vs. Condenser Temperature

Each of the heat rejection systems has its own parasitic power requirements, and the results were adjusted to compensate for these requirements.

The cost of water is another variable, and for the study was assumed as a middle-of-the-road \$200 an acre-foot.

Each type of heat sink was then optimized for lowest net present cost taking into account each of the before mentioned factors.

COMPARISON

Tables 4.2.1A and B summarize the process data and economic data for the optimum design for each of the three heat sink systems. Two water-cooled cases are shown. The first case is the normal case with water discharged into a sewer. The second case includes the cost of zero liquid discharge that has been imposed on some desert plants.

CASE	1	2	3	4	5	6	7	8	9	10
	Cond. Pinch (°F)	Cond. Temp. (°F)	Fan Pwr (kW)	Circ. Pump (kW)	ZLD Power (kW)	Gross Power (kW)	Net Power (kW)	Δ Gross Power (kW)	Δ Net Power (kW)	Water Use (gpm)
Water Cool	3	87	224	355	0	12,741	12,162	345	153	313
Water Cool, ZL	3	92	149	355	73	12,517	11,940	569	375	274
Air Cool	20	118	244	0	0	11,441	11,197	1645	1118	0
Nat Draft	45	138	0	0	0	10,776	10,776	2310	1539	0

Table 4.2.1A. Heat Sink Process Summary

CASE	1	2	3	4	5	6	7	8	9
	CT/AC Cost (MM\$)	Pump Cost (MM\$)	Cond Cost (MM\$)	ZLD Cost (MM\$)	Tot. Cost (\$MM)	Tot. Inst. Cost (\$MM)	Cost of Power (\$MM)	Oper. Cost (\$MM)	Net Heat Sink Cost (\$MM)
Water Cool	0.450	0.126	0.460	0.000	1.035	2.795	0.611	0.280	3.686
Water Cool, ZLD	0.300	0.126	0.460	1.346	2.233	6.028	1.498	0.400	7.926
Air Cool	1.089	0.000	0.000	0.000	1.089	2.941	4.473	0.000	7.414
Nat Draft	2.852	0.000	0.000	0.000	2.852	7.699	6.156	0.000	13.856

Table 4.2.1B. Heat Sink Cost Comparison

The analysis shows that a water-cooled heat sink is the best option for a solar ORC cycle. assuming that there are no unusually stringent water disposal requirements such as the zero liquid discharge.

The primary reason that the water-cooled option emerges as the optimum is that it can condense the working fluid to a much lower temperature, allowing more work to be extracted.

Forced air cooled power plants are less efficient, and natural draft cooled plants, with or without water are far too expensive because of the high cost of building a four hundred foot tall cooling tower.

OPTIMIZATION

The water-cooled heat sink was optimized for a nominal ten megawatt plant. These optimizations will hold true for smaller plants as well.

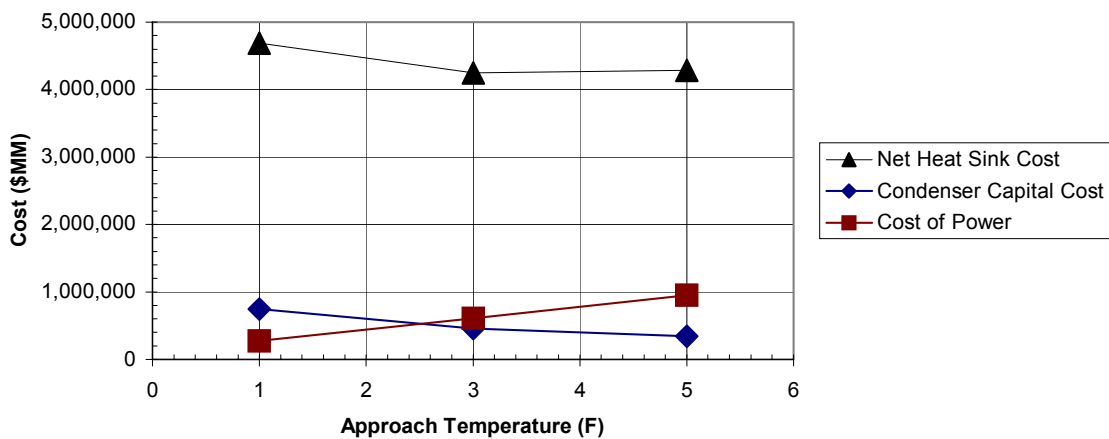

Figure 4.2.5. Condenser Cost vs. Approach Temperature

Figure 4.2.5 is a plot of net present costs versus condenser approach temperature. The plot shows that the optimum approach temperature for the condenser is roughly 3 °F. This is the point where the added benefit of additional power production is balanced by the added cost for condenser surface area. This optimum approach temperature is smaller than that usually found for other types of power plants because solar power plants are so much more expensive than most traditional power plants.

The optimum cooling tower size was found to be roughly 1.5 times that of a standard cooling tower cell used in conventional power plants. At that size, the value of the incremental gross power produced by using a larger tower is equal to the incremental cost of the tower and the extra parasitic power of larger fans.

CONCLUSION

The water-cooled heat sink is the best option for a STORES power plant. Air-cooled systems would be considered only in locations where water is prohibitively expensive or have zero liquid discharge mandates. Generally, the condenser and cooling towers should be larger than traditional plants because the improved efficiency will be cost-effective.

4.3 Working Fluid Evaluations

Organic “working fluids”, are the medium used for the Rankine cycle. They are hydrocarbons generally extracted from petroleum. At higher temperatures such as the 735 F possible with use of therminol as heat transfer fluid, the thermal stability of the working fluid becomes an issue. In choosing the right working fluid for a given cycle, the fluid should have thermal stability over the range of operating temperatures and a minimal degradation rate over time. The working fluids studied in this report are butane, heptane, cyclohexane, benzene, toluene, orthoxylene and ethylbenzene.

Although published thermal stability data is sparse, particularly in the range of temperatures and pressures used for organic rankine cycles, it is still possible to estimate the relative stabilities of various compounds based on actual operating data and theoretical considerations. A summary of this analysis is given in Table 4.3.1.

Fortunately, more extensive data is available for the fluids of greatest interest for STORES applications: butane and toluene. Butane has been used as a low temperature organic rankine cycle (ORC) working fluid for nearly two decades at a temperature of about 300 °F. Under these conditions, thermal degradation has not been a problem.

In the 1980's, toluene was considered as a high temperature working fluid for both solar and space ORC applications (Havens and Rogaller, 1988). Extensive long term testing was done at 750 °F yielding quantitative degradation rates of around 0.3 wt% per year. This is an acceptable rate for ORC purposes.

Table 1 shows that benzene is the most thermally stable of the candidate working fluids. Next after benzene is toluene. Compared to the stability of isobutane at 290 °F (typical for geothermal operations), benzene at 700 °F would have about 1.5% of the degradation rate and toluene at 700 °F would have 9,000 times greater degradation. However, this would still be less than 0.02 wt% per year based on the Havens and Rogaller report.

Working Fluid	Working Fluid Temperature, °F				
	290	330	550	650	700
Isobutane	1.59E+05				
Butane		2.48E+04			
Heptane			1.90E-05	3.47E-07	6.08E-08
Cyclohexane			2.03E-02	1.59E-04	1.92E-05
Benzene			3.10E+12	5.05E+08	1.13E+07
Toluene			4.78E+05	3.84E+02	1.72E+01
Orthoxylene			1.19E+02	2.80E-01	2.02E-02
Ethylbenzene			4.19E-01	1.12E-03	8.51E-05

Acceptable	
Marginal	
Unacceptable	

Table 4.3.1. Relative Stability Compared to Toluene at 750°F

For the bottoming cycle, the range of fluid maximum temperatures is anticipated to be in the 300 °F to 350 °F range, and isobutane has been successfully used at such temperatures in large and small geothermal plants for decades. This experience with isobutane coupled with the comparable thermal stability of n-butane, the fluid of choice for the bottoming cycle, obviates any need to further investigate its suitability.

Thermal Efficiency

The purpose of this section is to choose the ORC that will be best suited to the STORES system. Since the solar field represents a major investment, high thermal efficiency is an important characteristic of the organic rankine cycle. We have investigated two ways to achieve this. The first is through recuperation; that is, by using the sensible heat of the turbine exhaust stream to preheat the working fluid prior to vaporization. Recuperation reduces the external heat provided by the HTF, thereby increasing thermal efficiency.

The second method for improving cycle efficiency is to choose a working fluid that operates at a higher turbine inlet temperature. In the previous study, the HTF temperature was limited to 560 °F. By allowing the HTF temperature to be as high as 735 °F (currently achieved in operating trough solar power plants) greater thermal efficiency can be achieved.

Recuperation

The recuperator acts as a pre-heater to the vaporizer. It transfers heat from the turbine exhaust to the fluid entering the vaporizer. Heat that would otherwise be rejected to the condenser is recovered to heat up the working fluid. Figure 4.3.1 is a Temperature-Duty diagram for the recuperated cascade cycle. Figure 4.3.2 is a schematic showing the arrangement of two recuperators, one each for the top cycle and bottom cycle.

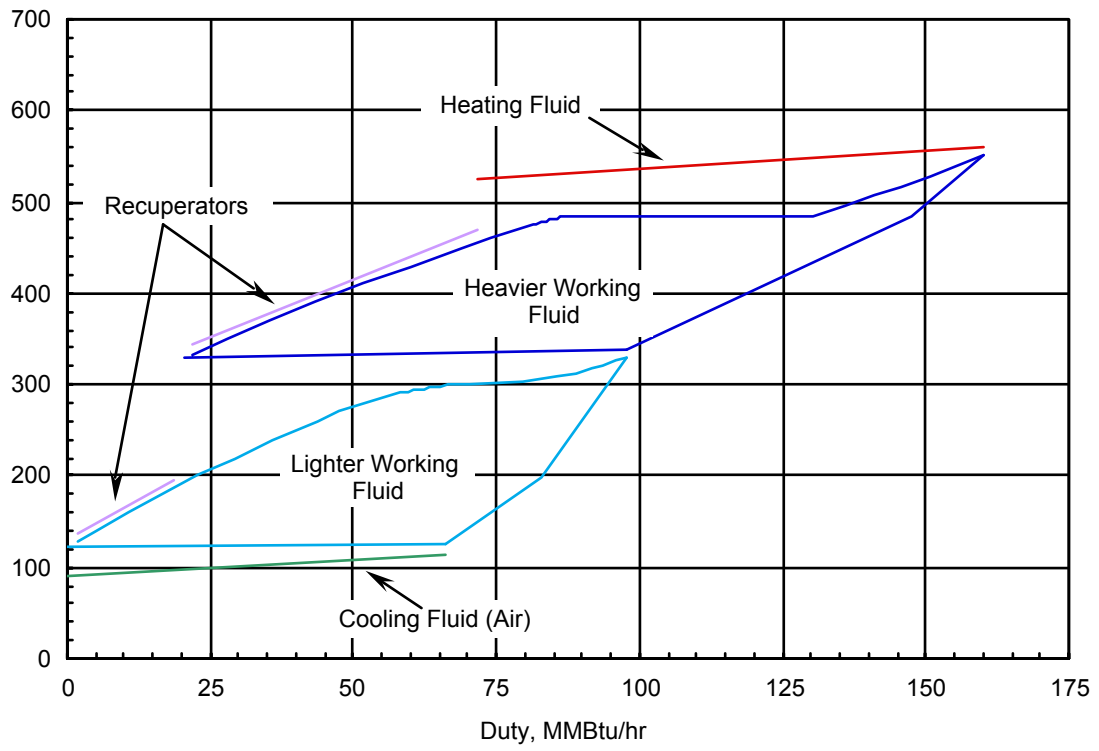

Figure 4.3.1. Recuperator Cascade Cycle Configuration

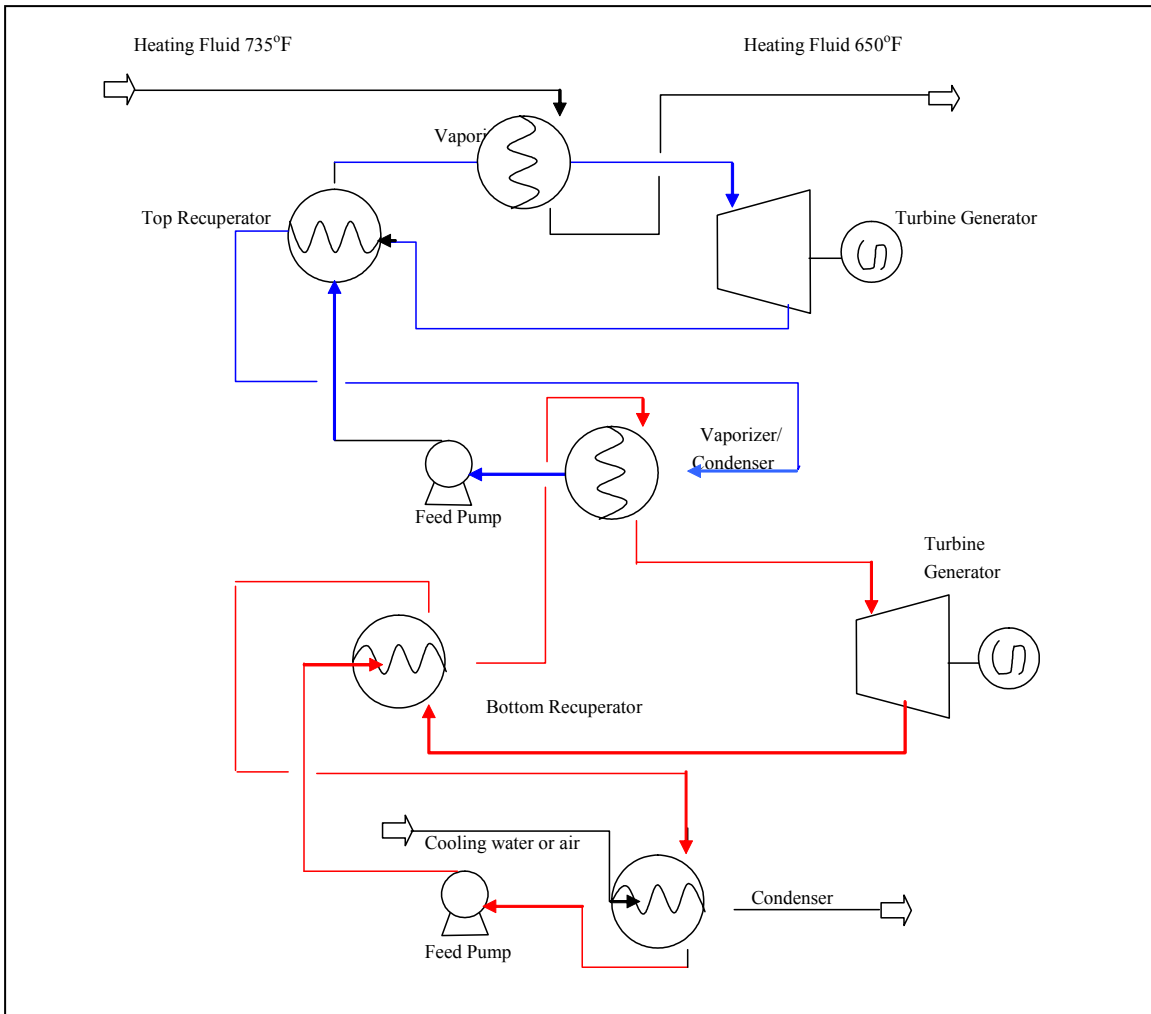

Figure 4.3.2: Schematic with Two Recuperators, Cascade

In addition to several aromatic heavy hydrocarbons, steam is also a candidate topping fluid for various cycle configurations. Figure 4.3.3 shows the Temperature-Duty diagram for a typical steam/hydrocarbon cascade cycle. The steam from the upper cycle will usually be superheated.

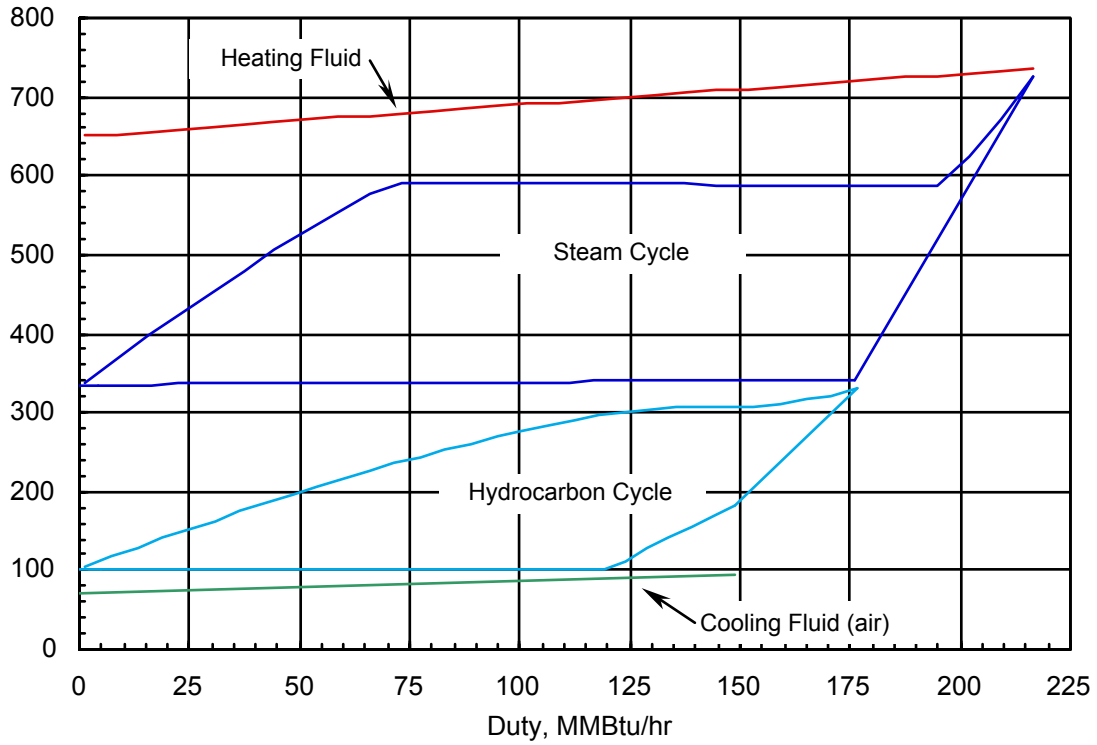

Figure 4.3.3: Typical Steam Cascade Cycle with 735°F HTF Temperature

Figure 4.3.4 shows toluene-butane cascade cycle. There are differences between steam and toluene (or any similar hydrocarbon) as a topping fluid. First, toluene operates at a lower pressure than steam (650 psia vs. 1450 psia). Second, toluene is supercritical at these conditions. Therefore, there is no two-phase vaporization (boiling) as there is for steam. Furthermore, toluene does not freeze at any ambient temperatures likely to be encountered. These differences favor toluene over steam.

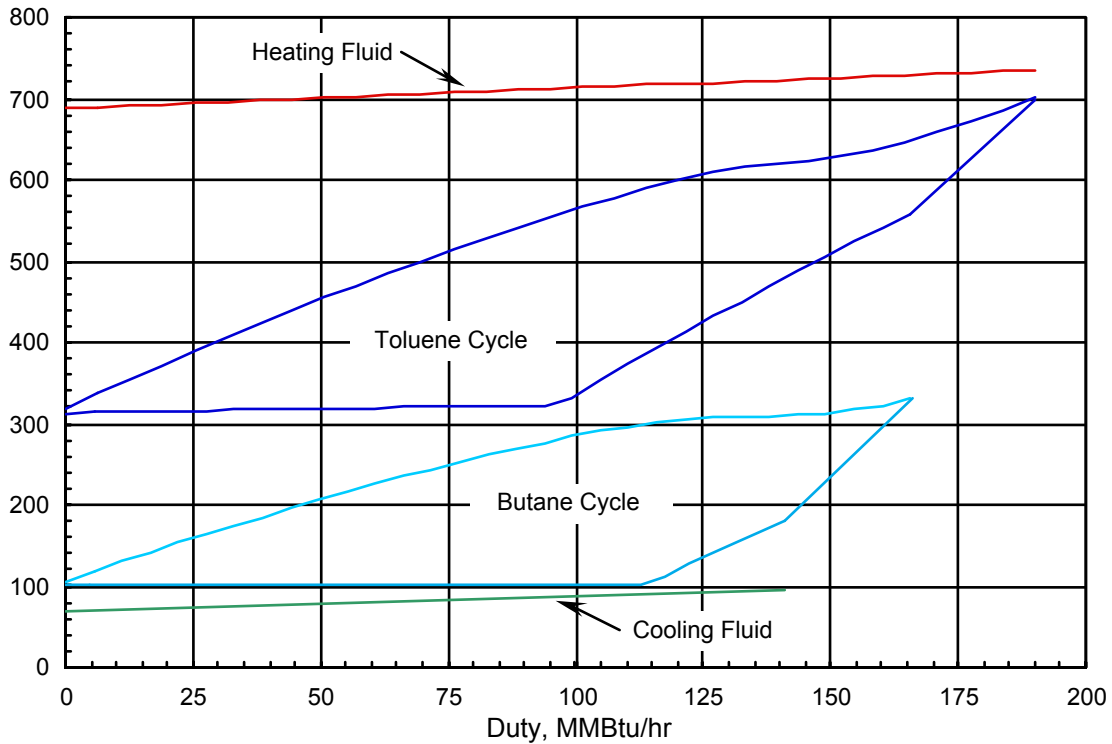

Figure 4.3.4: Toluene/Butane Cascade Cycle

For all of the above cases, the use of recuperation results in even higher cycle thermal efficiencies.

The Maloney-Robertson aqua ammonia cycle was also investigated. It takes a mixture of ammonia and water, partially vaporizes it and separates the ammonia-enriched vapor in a separator. The vapor passes through the turbine while the water-rich liquid is cooled in the recuperator and then mixed with the turbine exhaust stream before it goes into the condenser. This allows the condenser pressure to be lower than if only the ammonia rich vapor is condensed. This simple Maloney-Robertson cycle can operate as a topping cycle but must operate at too high a pressure when the temperature is in the 600 °F range. Therefore, the Maloney-Robertson cycle is considered as a bottoming cycle to an ORC topping cycle.

Figure 4.3.5 shows the Temperature-Duty Diagram for the cascaded Maloney-Robertson cycle, and Figure 4.4.6 is the process flow diagram for the cycle. The cascade Maloney-Robertson cycle has a lower thermal efficiency than the comparable cascade ORC cycles.

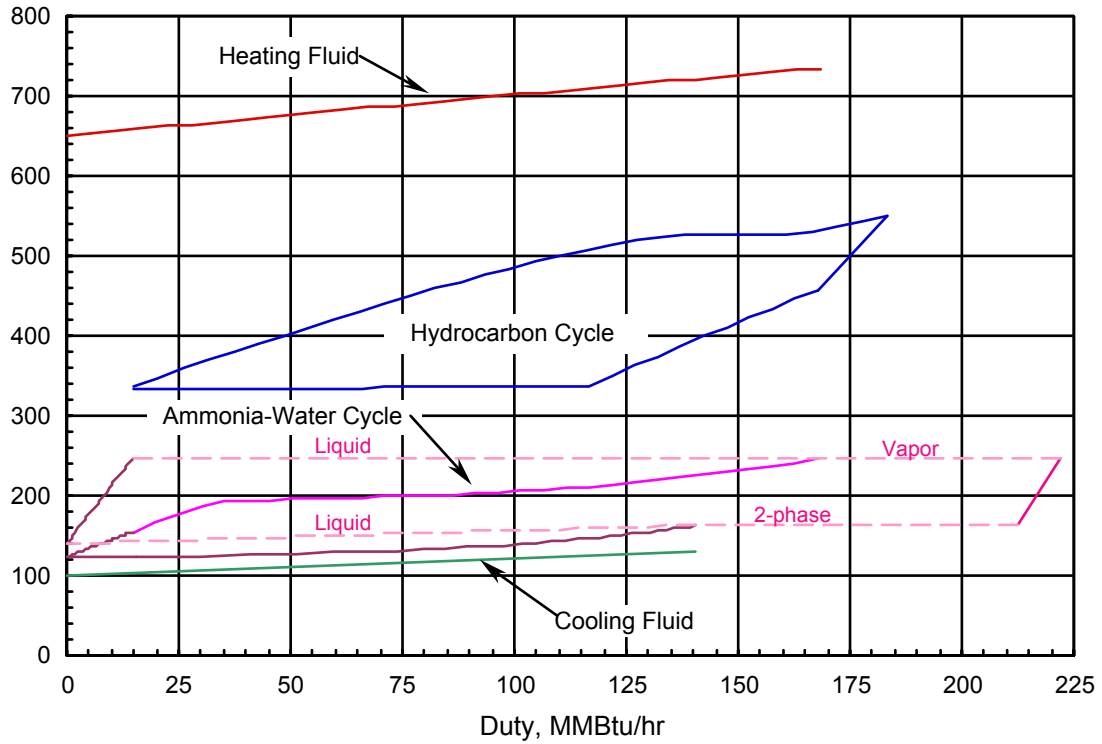

Figure 4.3.5: Typical Cascade Maloney-Robertson Cycle Configuration

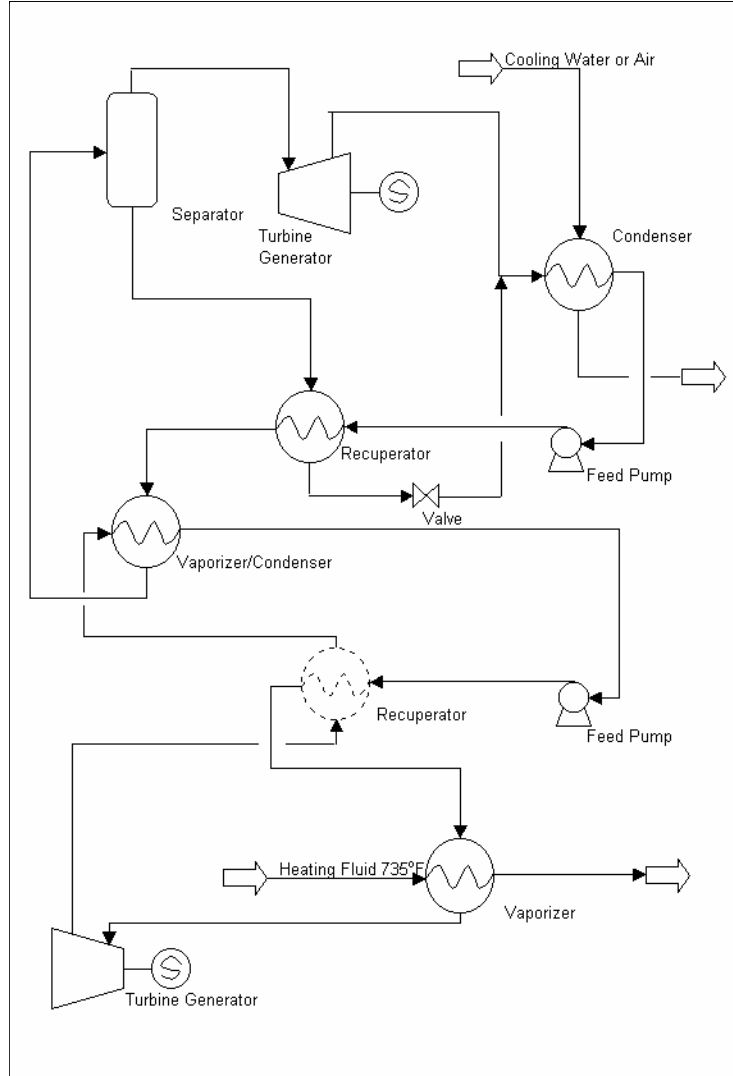

Figure 4.3.6: Recuperated Cascade Maloney-Robertson Cycle Configuration

A triple cascade cycle was also investigated using butane for the bottoming cycle, cyclohexane for the middle cycle and either steam or toluene as the topping cycle. Figure 4.3.7 shows the Temperature-Duty Diagram for the 3-cascade cycle and Figure 4.3.8 shows the corresponding process flow diagram.

Neither 3-cascade cycle is more efficient than the most efficient 2-cascade cycles. This is due to the additional internal losses of the third cycle. The additional complexity and cost of the triple cascade cycle dismiss it from further consideration.

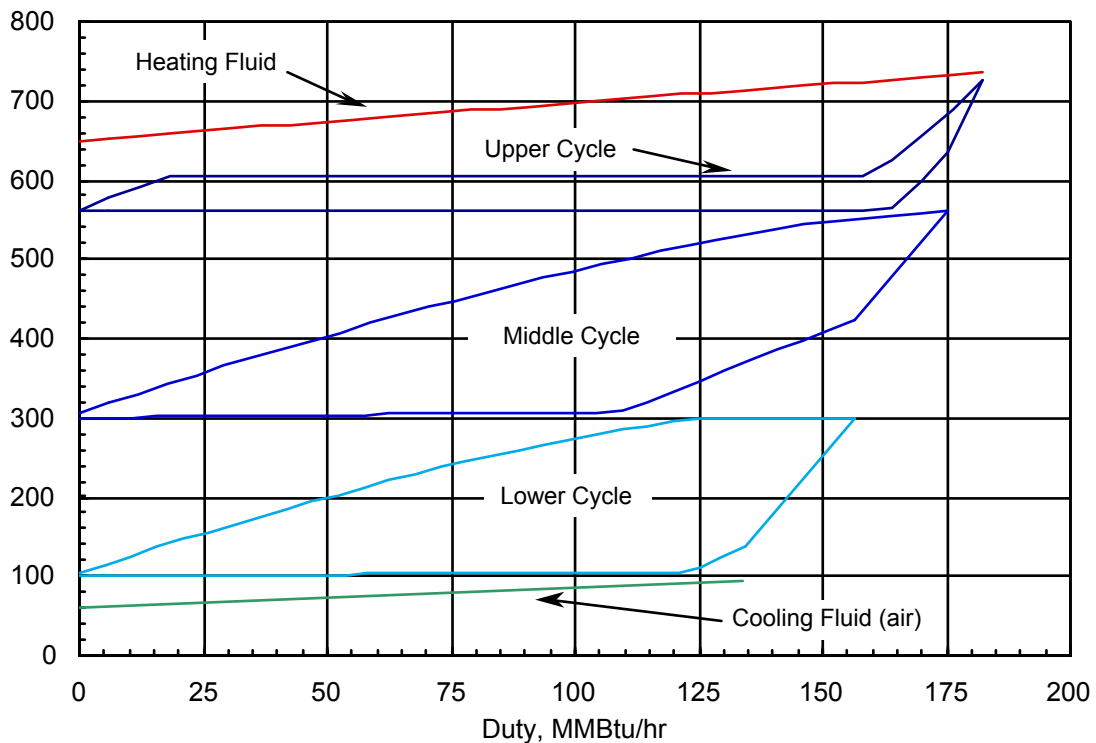

Figure 4.3.7. Typical Triple Cascade Cycle with 735°F HTF Temperature

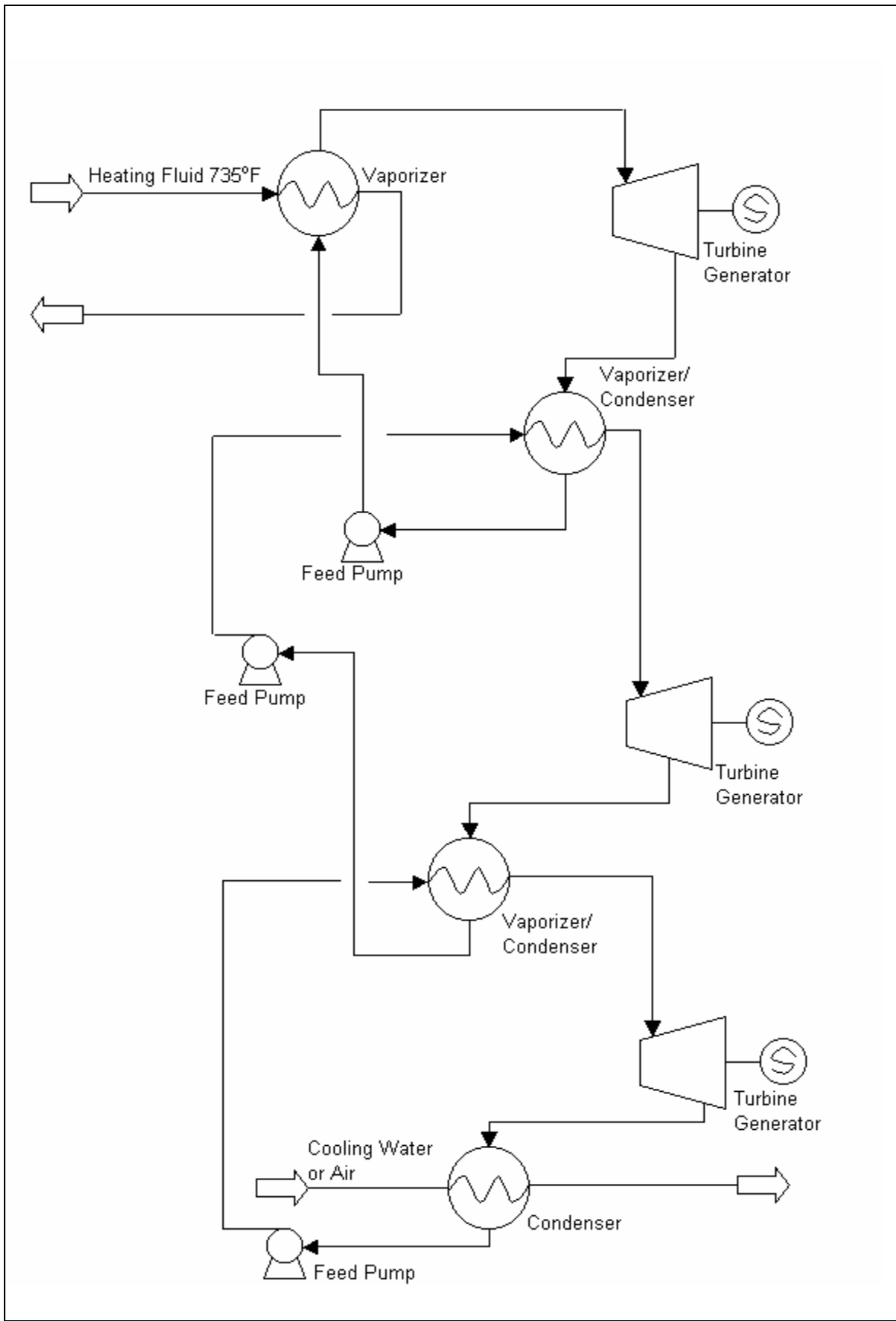

Figure 4.3.8: Process Flow Diagram for 3-Cascade Cycle

Table 4.3.2 summarizes the thermal efficiency of the different cycles with and without recuperation.

	Thermal Efficiency, %			
	Cascade		Recuperated Cascade	
	Gross	Net	Gross	Net
560 °F HTF				
Steam/Butane	27.1	22.4	29.2	24.1
Benzene/Butane	27.3	21.6	30.1	23.9
Toluene/Butane	26.4	21.3	29.2	23.6
Cyclohexane/Butane	26.6	20.2	29.4	22.3
Cyclohexane/ Maloney-Robertson	24.3	19.9	24.9	20.3
735 °F HTF				
o-Xylene/Butane	29.0	24.3	36.0	30.5
Toluene/Butane	29.4	24.4	36.5	30.4
Benzene/Butane	29.9	24.4	36.8	30.0
Steam/Butane	31.5	27.1	33.1	28.4
Toluene/Cyclohexane/Butane	32.7	25.9	36.2	27.5
Steam/Cyclohexane/Butane	28.7	22.8	31.2	24.6

Table 4.3.2: Cascade Cycle Thermal Efficiencies

From this table it can be seen that the Maloney-Robertson cycle is inferior to the recuperated butane cycle as a bottoming cycle. Increasing the HTF temperature from 560°F to 735°F improves the cycle thermodynamic efficiency by about 28%. The triple cascade cycles are less efficient than the comparable dual cascade cycles. The highest efficiency for an HTF temperature of 735°F is the o-xylene/butane cycle followed closely by the toluene/butane and benzene/butane cycles. However, since o-xylene is less stable than toluene at the cycle operating temperature, toluene would be the recommended working fluid.

The most efficient cycle for an HTF temperature of 560°F is the steam/butane cycle followed closely by the benzene/butane and toluene/butane cycles. For the reasons mentioned above, the ORC would be the preferred topping cycle. The slight thermodynamic advantage of steam would not compensate for its other disadvantages.

In all cases, recuperated cycles are significantly more efficient than the non-recuperated cycles.

Fluids and Cycle Digest

Of the potential organic working fluids reviewed in this study, only the aromatic hydrocarbons have sufficient thermal stability to be used as the topping cycle working fluid in a cascade solar thermal power plant. Light hydrocarbons such as butane have sufficient thermal stability to be used as bottoming cycle working fluids.

The most efficient solar organic rankine cycle is the recuperated orthoxylene/butane cascade cycle with a net efficiency of 30.5% and a gross efficiency of 36.0%. However, considering thermal stability, availability, and prior experience, the toluene/butane cascade cycle, with almost the same efficiency, would be the recommended choice. This cycle offers high thermal efficiency over a range of HTF temperatures.

The recuperated cascade cycle is the most thermally efficient organic rankine cycle. The best organic rankine cycles, even with recuperation, are less efficient than extraction steam cycles. However, they have other advantages which allow for lower operation and maintenance, making them suitable for small installations (1-10 MW).

4.4 Power Plant Optimization

This section addresses other factors that must be considered for power plant optimization. It has already been shown that a cascade cycle the best choice and that water cooled heat sinks are the best choice. The working fluids are toluene for the upper cycle and butane for the lower cycle.

Field Configuration

Additional efficiency improvements may be gained by configuring the solar field such that while the peak temperature of the HTF remains at 735 F, the *average* HTF temperature is significantly higher than at the SEGS power plants. This is achieved by modifying the series/parallel arrangement of the troughs such that fewer troughs are in series. For this task, the HTF hot-cold temperature difference was assumed to be 85 F, with an average temperature of 692 F. This is significantly lower than that of the current SEGS power plants. The toluene/butane cycle is able to take best advantage of this higher average HTF temperature.

Heat Transfer Fluid

The Heat Transfer Fluid (HTF) that makes the most sense for a STORES power plant is Therminol VP-1 because it can withstand higher temperatures than Caloria, and the largest experience to date has been with Therminol. While other fluids may make more sense in the future, others are researching this issue, and at the present these are not considered.

Other Considerations

There are several other considerations that may affect the selections. The supply chain that resulted in the original STORES plants have dwindled, and must be re-established. The expertise that resulted in several geothermal power plants has also dwindled. There are other suppliers that do build Organic Rankine systems for specialized uses, and these suppliers make lower temperature systems. If such systems are used, the plant performance may not be optimal, and this would need a trade-off between practicality and optimization.

Cost Trade-Offs

CAPITAL COSTS

The capital cost of the solar field is directly proportional to the efficiency. As plant efficiency goes up, the size of the solar field is reduced. Furthermore, as plant efficiency increases, the size and cost of the condenser decreases. The three most expensive part of the power plant are the solar field, the turbine-generator and the condenser. Turbine-generator costs tend to remain relatively constant for the same power output, which means that the two governing costs are solar field and condenser.

While there are some differences in the cost of working fluids, the overall cost of working fluid is minuscule relative to the overall cost of the plant and they may therefore be disregarded.

O&M COSTS

Another vital component of a STORES power plant is the O&M cost. In the U.S., by far the dominating O&M cost for the SEGS power plants is the cost of labor. A significant effort was put into reducing the O&M costs for a STORES power plant. The ORC Cascade cycle and the solar field both lend themselves to fully automatic operation with remote surveillance and control for handling problems. This automation will increase the capital costs but fortunately the costs related to Distributed Controls Systems and remote control have plummeted in the last few years, and will not be a major factor in the first STORES power plant. It is vital to the success of future STORES plants in the US that unlike the original SEGS plants, STORES plants must be fully automated.

Optimization Summary

The optimized STORES plant relative to this study will have the following features:

- A recuperated cascade cycle with toluene as the topping fluid and butane as the bottoming fluid.
- A field configuration that keeps the high and low HTF temperatures as close as practical.
- A water-cooled heat sink.
- A large cooling tower consistent with high incremental cost of electricity
- A large condenser consistent with high incremental cost of electricity
- A fully automated power plant, with no operators normally on site on a daily basis

4.5 Power Plant Conceptual Design and Cost Estimate

The plant conceptual design comprises the following:

- Power Plant General Arrangement and Plot Plan
- Solar Field General Arrangement
- Process Flow Diagrams for the power plant under various operating conditions

General Arrangement and Plot Plan

Figure 4.5.1 and 4.5.2 are the Plot Plan and General Arrangement Drawings for the 5-megawatt STORES power plant and solar field. The power plant will be area will roughly 250 feet 200 feet, or 50,000 square feet. The turbines are located together on one side of the plant to facilitate the electrical connections. The heat exchangers are located adjacent to each other in such a way as to minimize pipe runs between them. Also, they are arranged so tubes can be removed for cleaning. The cooling tower is located to one side of the plant near the condenser. This minimizes cooling water pumping parasitic power.

Figure 4.5.2 shows the solar field as well as the power plant. As the plot plan shows, the solar field takes up considerably more area than the power plant. It will be about 1800 feet wide by 640 feet long, or about 1.2 million square feet.

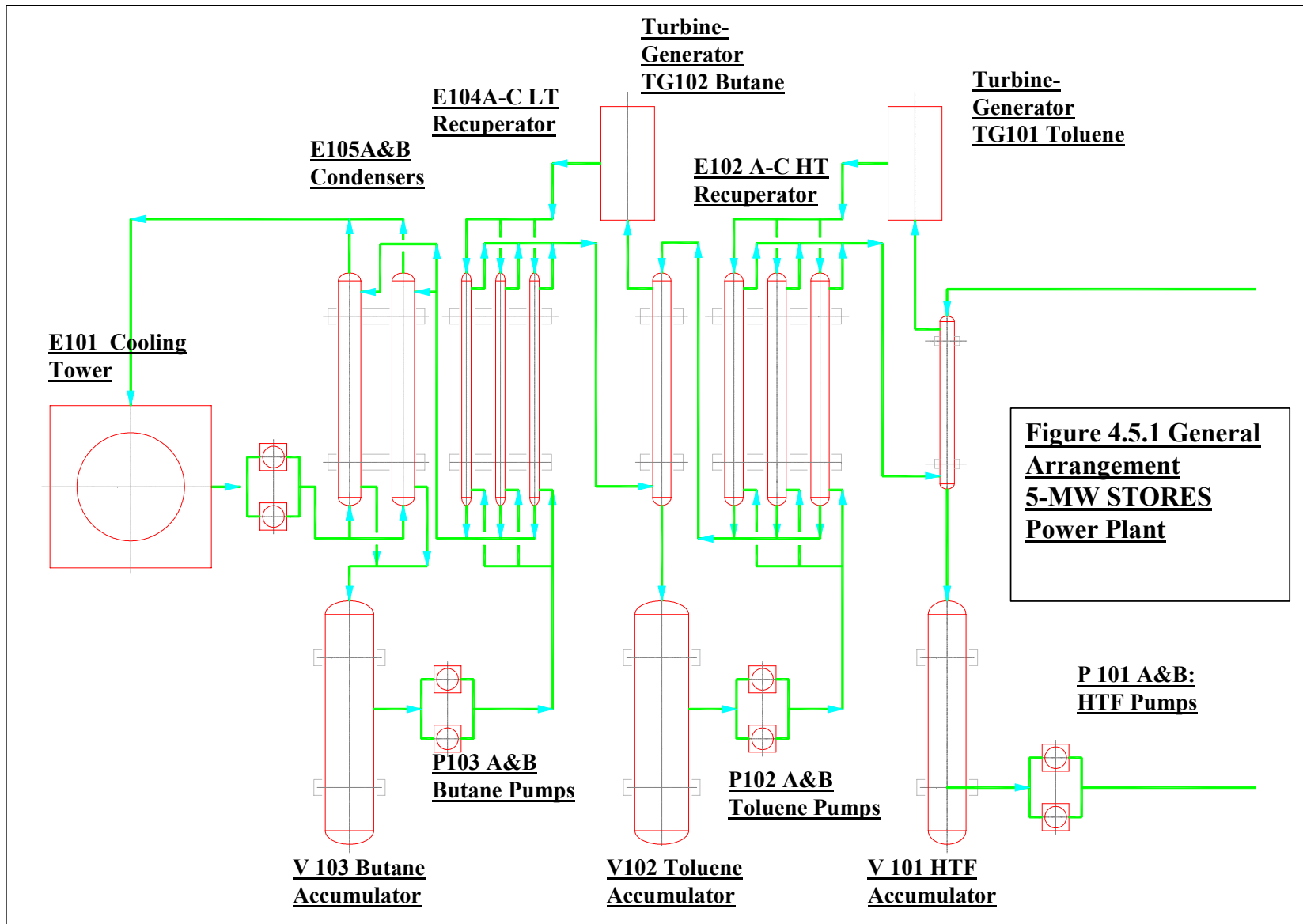
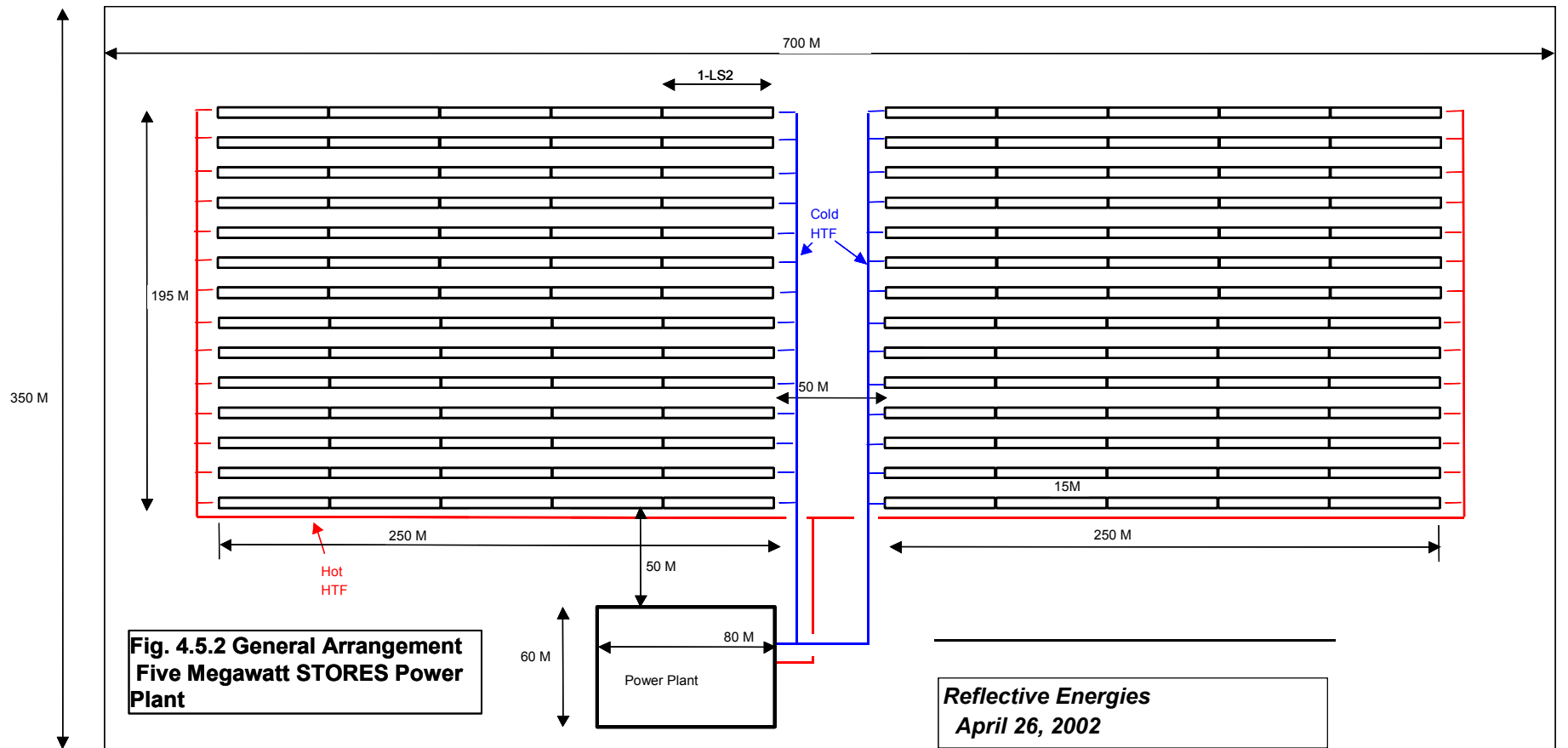

Figure 4.5.1 General Arrangement 5-MW STORES Power Plant



**Fig. 4.5.2 General Arrangement
Five Megawatt STORES Power
Plant**

*Reflective Energies
April 26, 2002*

Process Description

Figures 4.5.3 shows the process flow diagrams for the 5 –MW STORES and Figures 4.5.4 shows the process flow diagrams for the 1 MW systems. These are the summer conditions. As shown in the process flow diagrams, the heat energy is transferred from the source, the heat transfer fluid, to the sink, the air, in a series of heat transfer steps.

Heat transfer fluid circulating pumps pump the heat transfer fluid through a parabolic trough solar field. The fluid then returns with heat energy and enters a toluene vaporizer. There, the heat transfer fluid transfers its heat energy to the toluene working fluid. Then, the heat transfer fluid returns to an accumulator.

The toluene vapor flows to a high temperature turbine and expands to produce mechanical work. A generator converts this mechanical work into electricity. The toluene then exits the turbine and flows to a toluene recuperator. There, the heat from the turbine exhaust stream is used to pre-heat the toluene prior to its entry into the vaporizer.

The toluene then flows to a toluene-butane condenser-vaporizer. In this heat exchanger, the heat energy from the toluene is ‘cascaded’ down to a lower temperature butane cycle. The toluene is condensed as the butane is vaporized. The toluene then flows to a toluene accumulator where it then is pumped out by toluene circulating pumps.

The butane vapor flows from the condenser-vaporizer to a lower temperature turbine where it expands to produce more mechanical work. Another generator converts this mechanical work into additional electricity. The butane then exits the turbine and flows to

a butane recuperator. There, the heat from the turbine exhaust stream is used to pre-heat the butane prior to its entry into the condenser-vaporizer.

The butane then flows to a condenser where it is condensed by a stream of cold water from the cooling tower. The butane then collects in a butane accumulator where it is pumped out by butane circulating pumps.

The cooling water circulating pumps pump the cold cooling water through the condenser and back to the cooling tower. In the cooling tower, a fan draws in ambient air allowing it to contact the cooling water. Some of the cooling water evaporates and leaves with the ambient air. Since some of the cooling water evaporates, a make-up source of cooling water is required. In order to avoid excessive concentration of the cooling water, a blowdown stream of cooling water must be discharged.

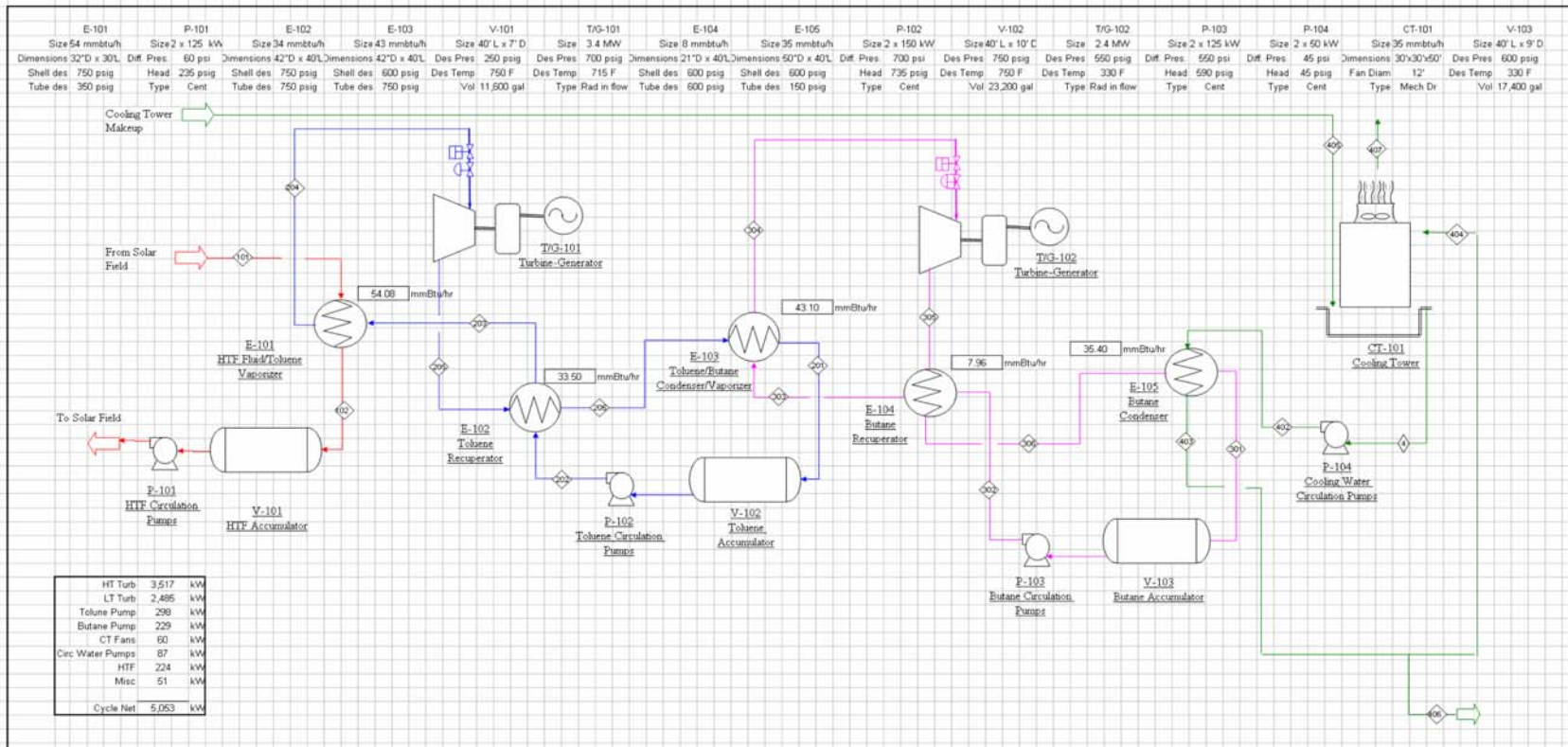

HT Turb	3,517	kW
LT Turb	2,486	kW
Toluene Pump	298	kW
Butane Pump	229	kW
CT Fans	60	kW
Circ Water Pumps	87	kW
HTF	224	kW
Misc	51	kW
Cycle Net	5,053	kW

Stream #	101	102	103	201	202	203	204	205	206	301	302	303	304	305	306	401	402	403	404	405	406	407
Fluid	Toluene	Toluene	Toluene	Toluene	Toluene	Toluene	Toluene	Toluene	Toluene	Butane	Butane	Butane	Butane	Butane	Butane	Water	Water	Water	Water	Water	Water	Water
Flow, kgph	1800	1800	1800	301	301	301	301	301	301	225	225	225	225	225	1802	1850	1850	1850	1840	49	10	40
Temp, °F	735	695	695	330	335	525	725	596	340	90	95	100	330	179	73	73	73	93	93	60	93	93
Pressure, psia	190	180	249	56	755	750	700	66	61	44	606	47	550	52	60	14	59	49	14	14	49	14
Density, lb/ft³	44.2	46.6	46.6	44.9	45.6	36.9	7.8	0.6	0.7	35.2	35.6	0.5	6.8	0.5	63.0	62.2	62.2	62.0	62.0	62.3	62.0	62.0
Kct, gpm (actm)	5.081	4.819	4.819	834	822	1,016	639	8,808	6,895	796	787	56,850	547	8,015	477	3,709	3,709	3,720	3,700	99	20	80

Figure 4.1: 5 MW STORES Power Plant: Case 1: Summer

PFD
Summer 5 MW
Case 1

STORES II Project

DRAWING NUMBER
2001-019-PF-001

Figure 4.5.3: 5 MW STORES Process Flow: Summer

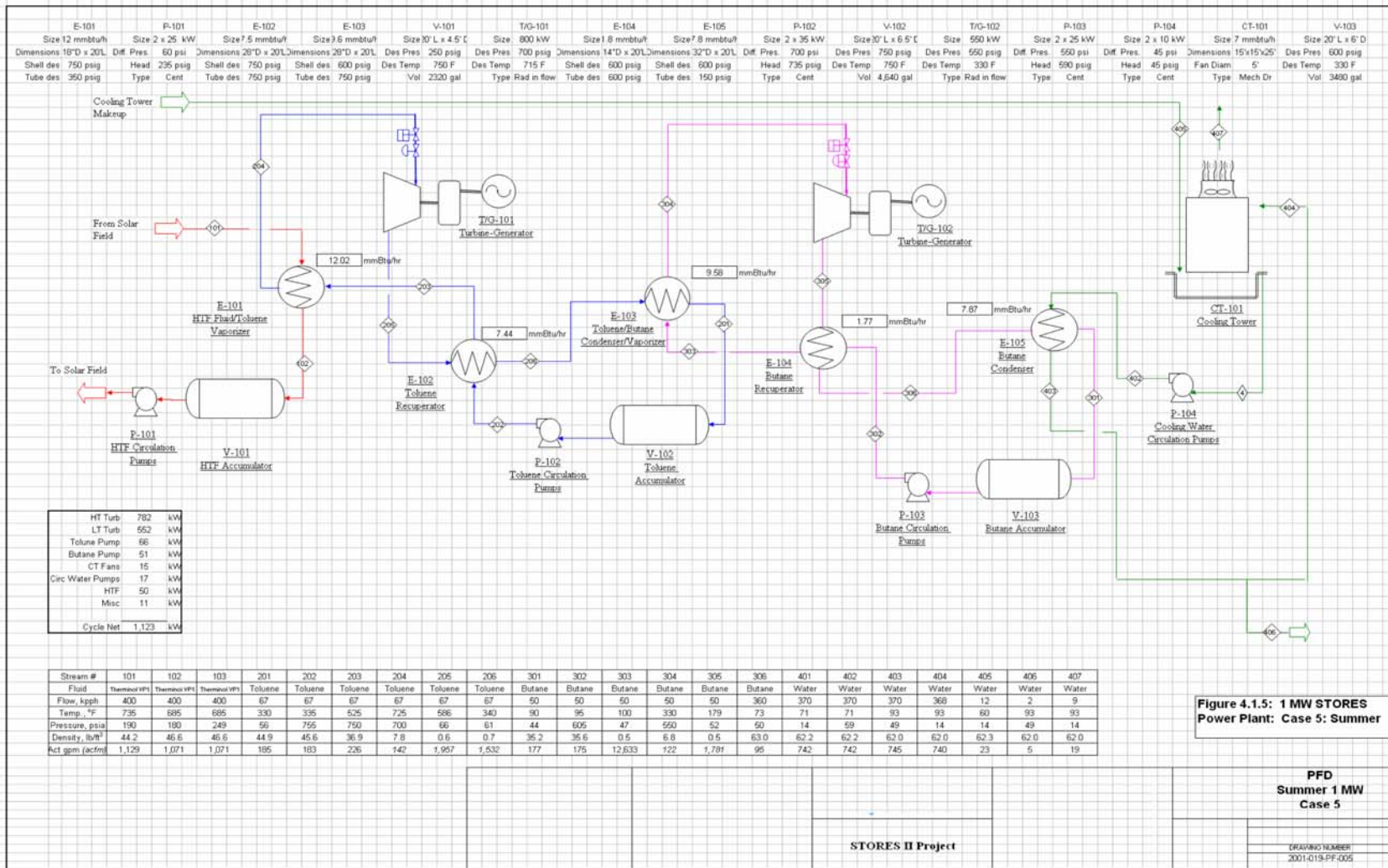

Figure 4.5.4: 1 MW STORES Power Plant Process Flow: Summer

Performance Curves

The plant output will vary with the wet bulb temperature. In general, as wet bulb temperature decreases the plant gross and net power output increase. A colder wet bulb condition allows the cooling water to be cooled to a lower temperature. This, in turn, allows the working fluid to be condensed at a lower temperature and expanded to a lower pressure. This additional expansion produces more power.

Figure shows the predicted power output for the solar ORC plant as a function of wet bulb temperature. The data points are taken from the heat balances in Appendix A. The four points represent the average, daytime, wet bulb temperatures in winter, spring, fall, and summer from left to right on the plot. The plot shows that the plant will make a high of 5.345 MW on an average winter day, and a low of 5.053 MW on an average summer day at Kramer Junction.

Figure 4.5.5 shows performance curves for a 5 WM STORES power plant. It is seen that gross and net efficiency are a function of wet bulb temperature. The plant runs more efficiently at colder temperatures meaning it produces more gross and net power for the same heat input. The plot shows that the net efficiency in winter is 32.3 percent and the net efficiency in summer is 31.9 percent.

Figure 4.5.6 is a performance curve for a 1 MW STORES power plant.

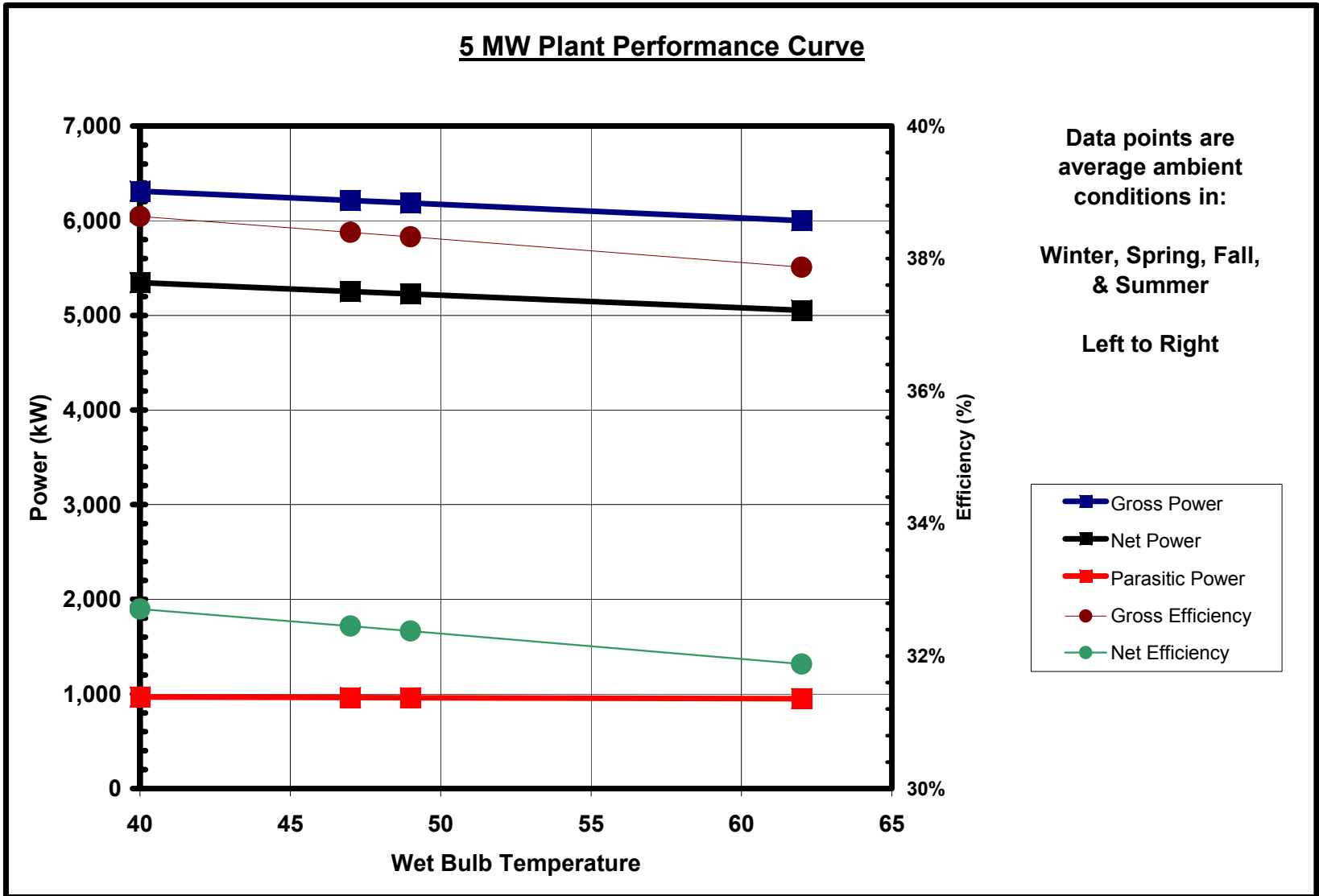

Figure 4.5.5: Performance Curves 5 MW STORES

1 MW Plant Performance Curve

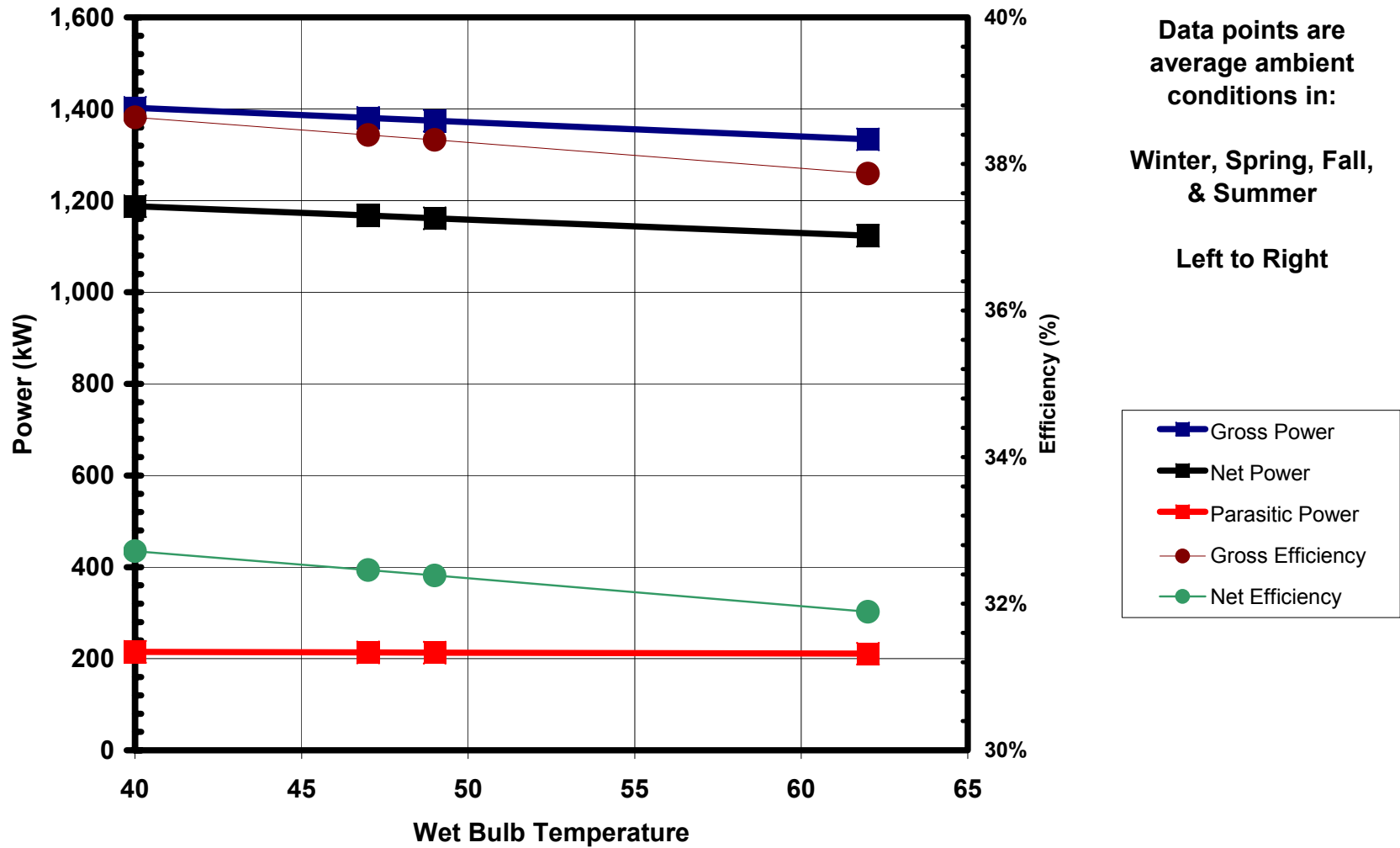

Figure 4.5.6 Performance Curves 1 MW STORES Plant

Cost Estimate

CAPITAL COSTS

Table 4.5.1 is a listing of the capital costs of the major equipment for the nominal 5 MW plant. All costs for this study were computed in 2003 U.S. dollars.

Equipment Cost

735 F Therminol VP1 Toluene Cycle				Design		Head psi	HHP	Total Price
Tag #	QTY.	Cap. Ea.	Description	Flow	Units			
E-101	1	100%	Vaporizer	55	MMBtu/hr total			68,000
E-102A-C	3	33%	HT Recuperator	32	MMBtu/hr total			354,000
E-103	1	100%	Condenser/Vaporizer	43	MMBtu/hr total			129,000
E-104A-C	3	33%	LT Recuperator	8	MMBtu/hr total			128,000
E-105A-B	2	50%	Condenser	35	MMBtu/hr total			300,000
CT-101	1	100%	Cooling Tower	100	MMBtu/hr total			150,000
P-101A&B	2	50%	HTF Pumps	2530	gpm	75	148	118,000
P-102A&B	2	50%	Toluene Circ. Pumps	417	gpm	699	227	153,000
P-103A&B	2	50%	Butane Circ. Pumps	398	gpm	561	174	130,000
P-104A&B	2	50%	Cooling Water Pumps	1850	gpm	45	50	33,000
TG-101	1	100%	Toluene T-G Package					2,040,000
TG-102	1	100%	Butane T-G Package					1,675,000
V-101	1	100%	HTF Accumulator					56,000
V-102	1	100%	Toluene Accumulator					86,000
V-103	1	100%	Butane Accumulator					71,000
H-301	1	100%	HTF Heater	7	MMBtu/hr total			76,000
Total Equipment Cost								5,567,000
Fluid			Cost of fluid					357,000
Total Plant Installed Cost								15,388,000

Table 4.5.1: Capital Cost of a 5 MW STORES Power Plant

The total cost of the major plant equipment is \$5,567,000 or roughly \$1100 per kW. For binary geothermal power plants, the total installed cost is roughly 2.7 times the major equipment capital cost. This works out to a total installed cost of \$15,388,000 or \$3,050 per kW. These costs may be considered to be the cost of power plants once the technology is mature. In discussions with suppliers of solar trough fields, the cost of the field, installed, is anticipated to be about \$2,000 a kW, or between \$10,000,000 and

\$12,500,000 in total. This brings the total cost of, the cost of the first STORES plant will be in the range of \$25,000,000 to \$26,000,000. For the first plant, it is anticipated that additional “first time” engineering costs will be needed, and the cost of the plant is anticipated to be closer to \$27,000,000 to 30,000,000. For the economic analysis, a mid-range figure of \$27,500,000 was used.

Equipment Cost

735 F Therminol VP1 Toluene Cycle				Design		Head psi	HHP	Total Price
Tag #	QTY.	Cap. Ea.	Description	Flow	Units			
E-101	1	100%	Vaporizer	3	MMBtu/hr total			15,000
E-102A-C	3	33%	HT Recuperator	7	MMBtu/hr total			79,000
E-103	1	100%	Condenser/Vaporizer	10	MMBtu/hr total			29,000
E-104A-C	3	33%	LT Recuperator	2	MMBtu/hr total			28,000
E-105A-B	2	50%	Condenser	8	MMBtu/hr total			67,000
CT-101	1	100%	Cooling Tower	22	MMBtu/hr total			61,000
P-101A&B	2	50%	HTF Pumps	562	gpm	75	32	48,000
P-102A&B	2	50%	Toluene Circ. Pumps	93	gpm	699	50	62,000
P-103A&B	2	50%	Butane Circ. Pumps	88	gpm	561	38	53,000
P-104A&B	2	50%	Cooling Water Pumps	411	gpm	45	11	13,000
TG-101	1	100%	Toluene T-G Package					827,000
TG-102	1	100%	Butane T-G Package					679,000
V-101	1	100%	HTF Accumulator					12,000
V-102	1	100%	Toluene Accumulator					19,000
V-103	1	100%	Butane Accumulator					16,000
H-301	1	100%	HTF Heater	1.5	MMBtu/hr total			31,000
Total Equipment Cost								2,039,000
Fluid			Cost of fluid					79,000
Total Plant Installed Cost								5,584,300

Table 4.5.2: Capital Cost of a 1 MW STORES Power Plant

For the 1 MW nominal alternative, the total installed plant cost will be approximately \$5,584,300, as shown in Table 4.5.2. The increase in cost per kilowatt is because the fixed costs for a smaller plant are the same as for a larger plant, and the equipment cost is proportionately larger, making the per-kilowatt costs higher. The cost

for the solar field is estimated to be \$2,500 a kW, or \$2,500,000. When additional costs associated with first-time effort and other uncertainties are added, the cost of the first STORES plant at 1 MW is anticipated to be between \$9,000,000 and \$10,000,000. These additional costs will be for the first plant, whether it is one megawatt or five megawatts.

O&M COSTS

Unlike the current Solar Thermal Trough based plants, STORES plants will be designed to run automated, including automated start-up and shut-down. This significantly reduces labor costs, which is important, because for the current plants, labor is spread over considerably larger power production. The O&M costs are anticipated to be about 0.05 a kW for a STORES plant. Figure 4.5.3 provides the table for O&M costs.

Figure 4.5.3: Stabilized O&M cost for 5 MW & 1 MW STORES Power Plant									
1	2	3		4	5	6	7	8	9
Megawatts	Labor (Equiv. Persons)	Rate \$/hr		Ann. Labor \$	Ann. Solar Field Non-Labor O&M	Ann. Power Plant Non-Labor O&M	Total Ann.. O&M costs	Annual Output KWH	\$/KWH
5	2	40		160,000	250,000	160,000	570,000	12,000,000	0.048
1	1	40		40,000	50,000	40,000	130,000	2,400,000	0.054

4.6 Field and Storage Evaluation and Conceptual Design Report

Background

At the time that this work was initiated, it was estimated that customers for STORES power plants would be generally off-grid, and would require a significant amount of storage in order to obtain electricity in the evenings and nights. STORES plants were initially therefore designed to use a fluid with a very low vapor pressure at high temperatures. The fluid of choice was Caloria, a commercially available high temperature fluid. Caloria is stable at 560 F, and there is a lot of experience with use of Caloria for thermal storage.

Thermocline Storage

The thermocline system relies on and enhances the inherent low convection currents in the fluid. It comprises “hot” and “cold” fluid zones that are broad, indistinct divisions inside the tank. When the tank is fully charged, the hot zone comprises all of its useful storage capacity. When the tank is fully discharged, the cold zone expands to include the entire capacity of the tank. The tank is charged by drawing cold fluid from the tank, and heating it by circulating it through the solar collectors, then returning it to the hot zone of the same tank, increasing the average temperature of the tank, and enlarging the hot zone within the tank. A fully charged tank would comprise only hot fluid. When power is needed, hot fluid is drawn from the tank, and used to generate steam or another vapor (depending on the working fluid) and “cold” fluid is returned to the same tank.

Dual Tank Storage

Dual tank storage is the most common type of storage for hot and cold fluids. It comprises a hot fluid tank and a cold fluid tank, each with a capacity of the entire useful inventory of heat transfer fluid. During sunny days, fluid is drawn from the cold fluid tank, heated by running it through the solar collectors, and then it is delivered to the hot fluid tank. When power is needed, fluid is drawn from the hot fluid tank, where its heat is used to vaporize steam or other working fluid, after which it is sent to the cold fluid tank. The SEGS I power plant used a two tank storage system.

Potential STORES Customers: The Size Vs. Cost Dilemma

It was hypothesized that customers for STORES power plants would be remote customers that are completely off-grid, and these customers would require storage of energy to enable power on demand. At that time, it was assumed that there would be several sites with peak demands of ten megawatts or more. Hence storage was initially an integral part of STORES design. However, in the U.S. such customers were not found. The electric power grid is ubiquitous, and most communities have access to it. Communities that are totally off-grid are usually very small, with peak demands of no more than a few kilowatts. For such customers, Photovoltaics (PV) is a much better option. STORES systems are just not practical in sizes of a few kilowatts. However, even though no customers were found that could use ten-megawatt, or even one-megawatt STORES power plants, there was found to be a significant demand for STORES power plants located on-grid. While the profile of these customers differs widely, some of the common traits include the following:

- High cost of traditional electricity
- Summer peaking, mainly air-conditioning
- At the end of long, weak feeders, perhaps overloaded during summer peaks
- Need for diversity of fuel source
- Pressure to increase renewable energy use
 - Portfolio standards
 - Buydowns available for solar power
 - Mandates or targets to increase renewable energy use
- Energy security needs
- The need for ultra-clean on-site power
- Summer peaks of ten to twenty megawatts or higher
- Large tracts of land available with high-quality direct normal solar radiation
- A commitment to solar power

These customers are already receiving large amounts of power from the grid. They are located in the Southwestern desert, and are most commonly government institutions. They include Army and Air Force bases, weapons stations, US Forest Service stations, National Parks services, University outposts, and so on. Some of these institutions will be able to use ten megawatts of summer peaking power, but others would be better served

with power plants that are smaller, in the size range of 1 to 5 megawatts. None of them would benefit to any extent were storage available.

Plants without Storage: Efficiency Considerations

When storage was considered vital to STORES power plants, the maximum temperature available was 560 F, the thermal stability limit for Caloria. Caloria at 560 F has a very low vapor pressure, and may be stored in atmospheric tanks. Most SEGS plants use Theminol VP-1, that is thermally stable up to 735 F, but has higher vapor pressure at that temperature and must therefore be pressurized. Large pressurized tanks are expensive and complex. However, with no need for storage, it becomes feasible to consider the increase in thermal efficiency that can be achieved with higher temperatures, and the economic considerations related to doing so.

The previous sections (4.1 through 4.5) addressed the various changes to the thermodynamic cycle that the higher temperatures can achieve. A dual cascade cycle using toluene as the upper working fluid and butane as the lower working fluid were selected over the other options: a simple Rankine cycle and a triple cascade cycle with three working fluids.

The Two Sizes Selected: Five megawatts and One megawatt

Whereas originally it was anticipated that the STORES standard plant would be 10 MW, it was found that customers were more interested in smaller plants, in the size range of 1 to 5 MW. The study therefore reflects the change the STORES design to two choices: One megawatt and five megawatts. This was a difficult decision to make, because while the solar field is largely modular, a larger power plant has significantly lower cost per kilowatt than a smaller power plant. On the other hand, it is well known that no new Trough power plants have been built in the last fifteen years. The trend to larger plants (as witnessed by the progression from a fifteen megawatt SEGS I to 80 megawatt SEGS VIII and IX) did not continue. Rather than continue towards larger plants, it is considered more prudent to consider market forces and develop a power plant that meets the needs of the market.

Field Design

It is possible to increase the average temperature of the HTF without exceeding its maximum temperature by selecting the series-parallel patterns in which solar collectors assemblies are arranged. For the same total number of collectors, the fewer collectors in series the higher the average temperature. Should STORES power plants reach full commercial potential, this consideration is anticipated to play an important part in optimizing the efficiency and output.

4.7 Host Site Selection and Market Potential Report

California Opportunities

Ultimately, STORES systems must have willing, supportive, even enthusiastic clients in order to succeed. Solar energy is intermittent and seasonal, and needs grit and determination to move forward. It is also vital to provide high value to the client. Several attempts were made to find such clients. It was initially felt that the best marketplace in the US would be off-grid customers who needed electricity. This approach was not successful. Despite much effort, no potential off-grid customers could be found in the U.S. who would benefit from 1 to 10 MW of solar electric power. The U.S. grid is generally robust and delivers power to any community that has a sustained demand for one megawatt of power. While this finding is good for U.S. customers, it was a blow to the project. The search included meetings with Sandia National Labs, to help seek Native American communities who may benefit from solar electric power. During the meeting, Dave Menicucci of Sandia suggested that there may be on-grid customers who would be very interested in STORES power plants connected to the grid, but on the customer side of the meter. These customers would be large US government institutions located in the Southwest desert. The U.S. government is the largest single landowner in the Southwestern U.S. Many of these institutions are part of the U.S. Department of Defense, with military bases, weapons stations, Forts and Air Force bases strategically located in many areas. Several of these locations have peaking loads of 10 to 20 megawatts, and peak load occurs on hot summer days. This is an excellent match with solar thermal power because the power plant will also peak during those same hot days for the same reason.

Many of these remote DOD locations are served by long feeders from utility systems. After September 11, 2001, there is increasing concern that the security of power supply to these remote stations may be inadequate. On-site power generation, even intermittent solar power, will help increase security. If the fuel supply is local, such as solar power, another risk factor is reduced. As an example, Fort Irwin has a peak load of about 20 megawatts, pays \$0.19 a kWh for summer peak power, \$23 per month for peak demand, and is at the end of a long line. Fort Irwin is very interested in a STORES power plant. Several other military bases have shown initial interest.

The California Power Authority (CPA) created a parallel market opportunity. The CPA's mandate is broadly to ensure that stable power is available from diverse resources. The CPA issued a Request For Bids (RFB) for PV systems on rooftop and open field systems. It subsequently amended its RFB to include solar thermal electric systems up to 5 MW. This opportunity was very important for the STORES power plants. Reflective Energies (through its sister organization, FlexEnergy) submitted a proposal for a total of ten 5-megawatt STORES power plants all located on the customer's property. The base proposal included five such plants and the optional proposal included another five plants. All of these plants would be essentially identical, delivering power directly to the grid, but by providing the power on the customer side of the meter, the power produced would offset retail power pricing. Retail prices for electricity are significantly higher than wholesale prices in California.

The California Power Authority approved the bid submitted by FlexEnergy and the CPA placed FlexEnergy on the approved bidders list for future solar power offerings. Under the terms of the award, the CPA will find a host for the power plants who will provide the land and the water. The CPA may own and operate the power plants, transfer them to the host, or purchase the electricity from the plants.

A second aspect of this opportunity is the increased energy security requirements resulting from the events of September 11, 2001. Congress has commissioned a study that is being performed by URS to determine ways to increase the reliability of power for

vital U.S. defenses. Many U.S. defense bases in the Southwest receive their power supply from just a single, vulnerable, long distance transmission line. These bases often have no significant on-site generation, and are also limited by fuel storage options. Among the solutions being considered is renewable energy. Renewable energy, particularly solar power can significantly improve reliability of such sites, even without storage. Solar power is locally available, in the Southwest matches the summer peak very well, and is largely immune from supply problems. Multiple plants scattered through the bases can increase reliability further because even if one site is incapacitated, others will continue to function. California Bases with high summer peaks and high electricity costs especially for summer peaking power include Fort Irwin, Twenty Nine Palms, Edwards Air Force Base and others.

In summary, the STORES research and development work has resulted directly in two major opportunities for Trough systems that were not previously conceived. Rather than follow the pathway of the SEGS power plants, where larger was considered better, the STORES study created the pathway to smaller power plants. STORES takes a page from Distributed Generation, and another from strategies for large Photovoltaic power plants. Instead of making low cost electricity, STORES seeks to make high value electricity, creating a new marketplace for Trough systems.

Arizona

There are many other similar opportunities in Arizona and the Southwestern US. Reflective Energies arranged a meeting with Pinnacle West, the Arizona Energy Company that is the parent of Arizona Public Service Company. Also in attendance at the meeting were energy representatives of the US Marine Corps Air Base at Yuma Arizona. The purpose of the meeting was to convince Pinnacle West that trough-based solar thermal power plants can be constructed in small modular sizes, and that such plants can be used to provide Distributed Generation benefits. A project was considered between Pinnacle West, the Marine Air Base and Reflective Energies whereby a STORES power plant would be installed and deliver power to offset peak power for the Base. Pinnacle West had several questions related to the STORES technology. As it learned more about the technology, Pinnacle West became more confident that the

technology has potential. In February of 2002, at the request of Reflective Energies, a team from Pinnacle West visited the Mammoth Geothermal Power Plant. Mammoth uses an Organic Rankine Cycle to generate electricity. Pinnacle West intention in making the visit was to evaluate the potential for the Organic Rankine Cycle for a STORES power plant. The meeting was successful. Pinnacle West's interest in Trough Based Power Plants continued to increase. With the renewable energy portfolio standard in effect in Arizona, Pinnacle West must install solar power plants to meet mandated requirements. Pinnacle West believes that small modular STORES-type solar thermal power plants can play a major role in helping it meet its portfolio standard goals. This conclusion by Pinnacle West is directly the result of Reflective Energies' STORES project developmental work. The STORES effort has already produced results far in excess of the original plan.

In April of 2002, Pinnacle West issued a Request for Proposals for a One-Megawatt Trough Based Organic Rankine Power Plant. This RFP itself provides further evidence that STORES power plants do make sense, that there is a market for such plants. The power plant, known as the Saguaro Solar Power Plant, is now under construction.

The RFP from APS had some changes from the concept originally proposed by Reflective. APS is now looking to generate power from solar to compete with wholesale, rather than retail prices and this poses a somewhat bigger challenge than the previous plan. Furthermore, APS decided that the first STORES plant to be only one megawatt; STORES already downsized from ten megawatts to five megawatts, and a further downsizing to one megawatt makes the overall project far more expensive on a dollars-per-kilowatt basis. The design of the power plant has been adapted to suit the partners in the project.

Other States

There are many other opportunities in the Southwest. Colorado and New Mexico are considering or implementing portfolio standards, and STORES power plants stand an excellent chance of being selected for meeting those portfolio requirements. STORES plants can be expanded from military bases to other governmental sites such as

Universities, Forest Service sites, Desert Laboratories and other such applications. The door has opened to consideration of Trough power plants as Distributed Generation. The STORES effort has been successful.

Worldwide Opportunities

There are many locations around the world that would greatly benefit from STORES plants as Distributed Generation for local consumption. The entire Sahara Desert, as large as the continental US, with its dozens of nations, holds great potential for STORES plants, grid connected and stand-alone. The entire Middle East with its large number of nations, India, Mexico and other countries. For the present, it is vital that the first few plants be built in the US satisfying important local needs before the technology is exported to other nations, because the complexity of export alone is challenge enough without adding the complexity of technological risk, expertise shortage and so on.

Conclusion: Market Opportunities

In conclusion, it appears that there is a real, potentially cost-effective market for STORES systems here in the U.S. and also in other countries. The STORES system should be designed and operated in a manner that meets the client's needs. The first STORES power plant is already under construction. It will help Pinnacle West to meet the Arizona Portfolio standard and will also provide the pathway towards low cost power from STORES systems.

4.8 Economic Evaluation

In order to perform this task, a Pro Forma for the costs, revenues and economics for STORES power plants was created. This Pro Forma was constructed to be flexible, allowing several assumptions to be input as variables, so that the effect of each variable could be examined, and the cumulative effect of multiple variables could also be examined. The generalized Pro Forma was created in a Lotus 123 format, and is available as a separate document. In order to gain some economies of scale the Pro Forma was set up to include the first three STORES plants in sequence,. The assumptions used were generally very conservative. The estimated overall cost of the first 5-megawatt STORES power plant was set at about \$5.50 /kW installed, making the

total power plant cost \$27,500,000. Subsequent plants were considered to be lower in cost because of our efforts to flatten the learning curve and because much of the design and developmental work would not have to be repeated. The power output from each plant would be about 2,560 kWh per installed kilowatt per year, or a total of 11,213,000 kWh/year for a five-megawatt power plant. This represents a capacity factor of 25.6% on an annual basis. The output could be increased somewhat by building a larger solar collector system and storage for some increase in cost. There are some tradeoffs between storage and maximizing efficiency. Exhibit 1 of the Pro Forma shows the first three STORES plants at the same site, thus simplifying the licensing, approvals, engineering and other costs for plants two and three. The Pro Forma also examines subsequent power plants. Exhibit 2 of the Pro Forma for the tenth STORES plant installed on a site all by itself.

The O&M costs of a STORES power plant are anticipated to be in the range of \$0.03 to \$0.05 /kWh. For the Pro Forma, because there are a total of three plants at the first site, a composite cost for all three plants of \$0.04 /kWh was assumed. While these O&M costs are lower than the existing SEGS power plants, they are not unreasonable. The SEGS plants were built during the eighties, with the Standard Offer contracts were in place, and natural gas use was allowed. Furthermore, running the power plants, especially in the early years, was a significant challenge. Each plant was unique in its own way; the technologies for design, installation, O&M were just being developed, and failures were much more commonplace. By contrast, STORES plants will be pure solar, have a much simpler operating philosophy, and will benefit from the lessons from the nine SEGS plants. The Pro Forma allows evaluation of various first costs and various O&M costs.

One means to examine the reasonableness of costs is to consider the cost of alternative generation. It was originally envisaged that STORES power plants would be off-grid; in this context alternative generation would be the cost of fossil fuel fired generators or other solar generators, such as PV, at the site. As the study progressed, it was found that the best application for early STORES power plants was on-grid, on the customer's side of the meter. Alternate generation in this context represents the collective generators that

together provide power for the grid. A practical surrogate for this is the power delivered by the grid to the customer. This power may be wholesale, which is the power purchased by the Utility for resale to its customers, or retail, which is the power sold by the Utility to its customers. STORES power plants, unlike the large scale SEGS solar thermal plants, are small scale, Distributed Generation power plants that may be placed on the customer's side of the meter, thus commanding retail electricity pricing that is much more attractive than wholesale pricing. STORES power plants are intended to sell power directly to the user, displacing expensive retail Utility power. This is particularly attractive during peak summer months when electricity prices are at their highest. This strategy dramatically changes the notion of the cost of alternate generation.

Pro Forma Results Summary

The Pro Forma analysis shows the following:

Basis:

Size: 5 MW

No. of Plants: 3

Capital Cost: \$5:50 per kW installed

Capacity Factor: 25.6%

Loan Amount: 80% debt-to-equity ratio at 5.0%/year interest rate.

Energy Credit: 0

Production Tax credits: \$0.017/kWh

O&M Costs: \$0.04/kWh

Energy Pricing (Based on SCE's then TOU rates):

Summer Peak: \$0.19544/kWh

Mid-Peak: 0.10897/kWh

Off-Peak: \$0.08808/kWh

Annual Energy Price Escalation Factor: 5%

With the assumptions above, the anticipated rate of return on capital is 4.77%.

If there is a \$0.015/kWh energy credit, the rate of return is 18.39%.

If in addition, there is also an energy tax credit of \$0.03/kWh, the rate of return is 22.18%.

STORES economics are particularly sensitive to capital cost as well. If the cost of the plants can be reduced to \$5 /W, for the same returns, energy prices could drop by 11.6%. If costs can be brought to \$4 /W, energy prices could drop by 34.7% for the same returns. It is not at all unreasonable to posit that STORES power plants could be built in the future for \$4/W, especially if more than one plant is built at the same time, allowing for larger volumes of solar collector production.

A key factor in the equation is low interest rates that have been prevalent for the last five years. For capital-intensive industries, such as STORES, low interest rates provide a major benefit. In this era of low interest rates and high energy prices there is a definite market for STORES systems providing power to end-users here in the U.S.

4.9 Planning for the First STORES Power Plant

Integrated Combined Cycle Solar power plants have been actively pursued for about 15 years, at a cumulative cost of hundreds of millions of dollars, but the first such plant is yet to break ground. The STORES concept was intended to find a shorter, less complex path towards resurrecting trough technology. Under this task Reflective Energies pursued the planning for a demonstration plant. As a result of its early investigations into possible paths towards demonstration, Reflective Energies pursued two routes: a plant in California, and a plant in Arizona. The California plant would include the California Power Authority (CPA) and a large consumer of power such as a major military base in the desert. The Arizona plant would be a demonstration plant for Arizona Public Service Co (APS) who is seeking to meet its renewable energy portfolio requirements. Both entities had a strong need for power, and particularly for large quantities of solar power.

Reflective decided to develop plans for each of the two possibilities. Each of the entities took a different path towards the first demonstration.

The first path was in California. The CPA issued an RFP for solar power. Initially, this RFP did not include solar thermal power plants, but as a result of questions raised during meetings with potential bidders, CPA decided to include solar thermal in its RFP. FlexEnergy (a sister organization to Reflective Energies) submitted a proposal to the

CPA through which it would build the first demonstration plant and then subsequent STORES plants. The proposal stated that FlexEnergy was prepared to build a series of solar thermal STORES power plants, and provided a cost, rudimentary design, and power generation information. Each plant would be five megawatts in size, and each subsequent plant would be less expensive, both for capital and for O&M. The plants would initially be owned by FlexEnergy, supplying power to a retail electric consumer, and the CPA would have the option to take over the power plant in time. Alternately, FlexEnergy was ready to build plants for the CPA, should that be the CPA's desire. The proposal was successful, and CPA selected FlexEnergy as a supplier of solar power plants that the CPA was planning to develop in California. The CPA has since become less of a force in California, and the promise of supporting the construction of power plants has not materialized so far.

The second path was in Arizona. Arizona utilities are required to meet a portfolio standard, and generate increasing amounts of electricity from renewables. APS is a leader in developing new forms of solar electricity, and as a result of Reflective's efforts, became very interested in STORES technology. Following meetings in Arizona, APS decided to investigate the reliability of ORC technology such as would be used in a STORES power plant. Reflective arranged a tour of the Mammoth geothermal power plant that has an ORC power system. APS interest in a STORES demonstration STORES plant increased sharply. It asked several questions regarding O&M, and requested that Reflective develop a means to significantly reduce O&M costs. Reflective organized a meeting at the SEGS III through VII power plants run by KJC Operating Co. The meeting was very successful, and a plan was developed to build an automated five megawatt STORES power plant with O&M costs significantly below those of the SEGS power plants, despite the smaller size of the STORES plant.

As a result of Reflective's efforts, APS then decided to go out to bid for a STORES plant, to a list of suppliers provided by NREL. APS issued an RFP, but instead of its original desire to build a five megawatt power plant, requested that bids be supplied to build a one megawatt solar thermal power plant, largely along the lines Reflective had provided to it.

APS received three bids and following a review, selected Solargenix as its supplier. The scope of work was negotiated, and a one-megawatt demonstration STORES plant known as the Saguaro Solar Power Plant broke ground on March 24, 2004 and is now under construction,. APS had considered the Saguaro site for a power plant for at least twenty five years, considering several technologies including the molten salt power tower. However, it was ultimately the STORES technology that brought the idea to fruition.

In summary, the STORES concept was so successful that a demonstration STORES power plant was initiated as a result of Reflective's efforts even as the plan for such a demonstration plant could be established.

REPORT DOCUMENTATION PAGE

Form Approved
OMB No. 0704-0188

The public reporting burden for this collection of information is estimated to average 1 hour per response, including the time for reviewing instructions, searching existing data sources, gathering and maintaining the data needed, and completing and reviewing the collection of information. Send comments regarding this burden estimate or any other aspect of this collection of information, including suggestions for reducing the burden, to Department of Defense, Executive Services and Communications Directorate (0704-0188). Respondents should be aware that notwithstanding any other provision of law, no person shall be subject to any penalty for failing to comply with a collection of information if it does not display a currently valid OMB control number.

PLEASE DO NOT RETURN YOUR FORM TO THE ABOVE ORGANIZATION.

1. REPORT DATE (DD-MM-YYYY) March 2006		2. REPORT TYPE Subcontract Report		3. DATES COVERED (From - To) November 2000 – May 2005	
4. TITLE AND SUBTITLE Solar Trough Organic Rankine Electricity System (STORES) Stage 1: Power Plant Optimization and Economics				5a. CONTRACT NUMBER DE-AC36-99-GO10337	
				5b. GRANT NUMBER	
				5c. PROGRAM ELEMENT NUMBER	
6. AUTHOR(S) Prabhu, E.				5d. PROJECT NUMBER NREL/SR-550-39433	
				5e. TASK NUMBER CP06.1001	
				5f. WORK UNIT NUMBER	
7. PERFORMING ORGANIZATION NAME(S) AND ADDRESS(ES) Reflective Energies 22922 Tiagua Mission Viejo, CA				8. PERFORMING ORGANIZATION REPORT NUMBER NAA-1-30441-05	
9. SPONSORING/MONITORING AGENCY NAME(S) AND ADDRESS(ES) National Renewable Energy Laboratory 1617 Cole Blvd. Golden, CO 80401-3393				10. SPONSOR/MONITOR'S ACRONYM(S) NREL	
				11. SPONSORING/MONITORING AGENCY REPORT NUMBER NREL/SR-550-39433	
12. DISTRIBUTION AVAILABILITY STATEMENT National Technical Information Service U.S. Department of Commerce 5285 Port Royal Road Springfield, VA 22161					
13. SUPPLEMENTARY NOTES NREL Technical Monitor: H. Price					
14. ABSTRACT (Maximum 200 Words) Report regarding a Stage 1 Study to further develop the concept of the Solar Trough Organic Rankine Cycle Electricity Systems (STORES).					
15. SUBJECT TERMS Solar Trough Organic Rankine Cycle Electricity Systems; STORES; solar trough; concentrating solar power; solar electricity					
16. SECURITY CLASSIFICATION OF:			17. LIMITATION OF ABSTRACT UL	18. NUMBER OF PAGES	19a. NAME OF RESPONSIBLE PERSON
a. REPORT Unclassified	b. ABSTRACT Unclassified	c. THIS PAGE Unclassified			19b. TELEPHONE NUMBER (Include area code)